

LDU 78.1

Fast Load Cell Amplifier with Digital Output



Engströms Vågteknik AB



Fast Load Cell Amplifier with Digital Output, Model LDU 78.1

- OIML approved R76 5000D 0.7uV per division
- Linearity better than 0.002 %, signal resolution ~ 100 nV
- Designed to drive one 350 Ohm Load Cell $\pm 2.2\text{mV/V}$ max
- 2400 internal samples per second
- Supply voltage 12-24 VDC +10/-15 %
- RS-422 / RS-485 2 or 4 wire Computer Interface
- Baudrates selectable from 9600 Baud to 115K2 Baud
- 2 logic inputs & 2 logic outputs
- Full computer control and set-up via the computer interface
- Easy, logical command protocol and syntax
- Full wrap around steel case for better EMC performance
- Simple pin connections or Optional Din Rail Adaptor

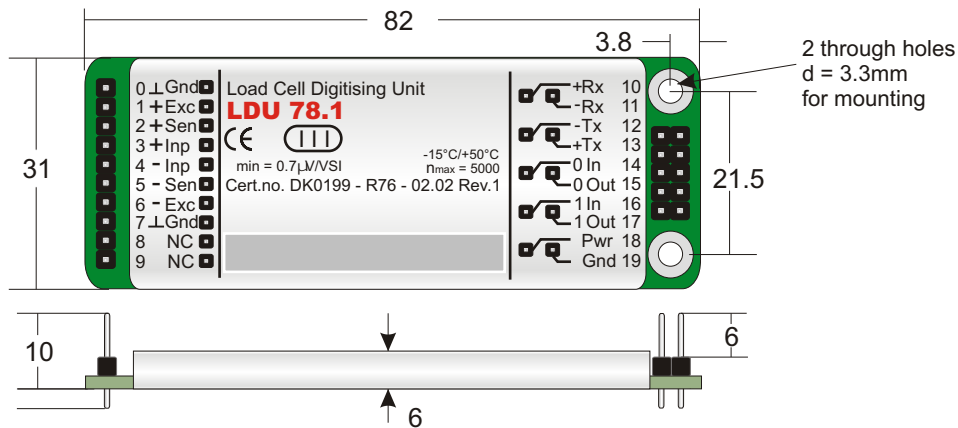
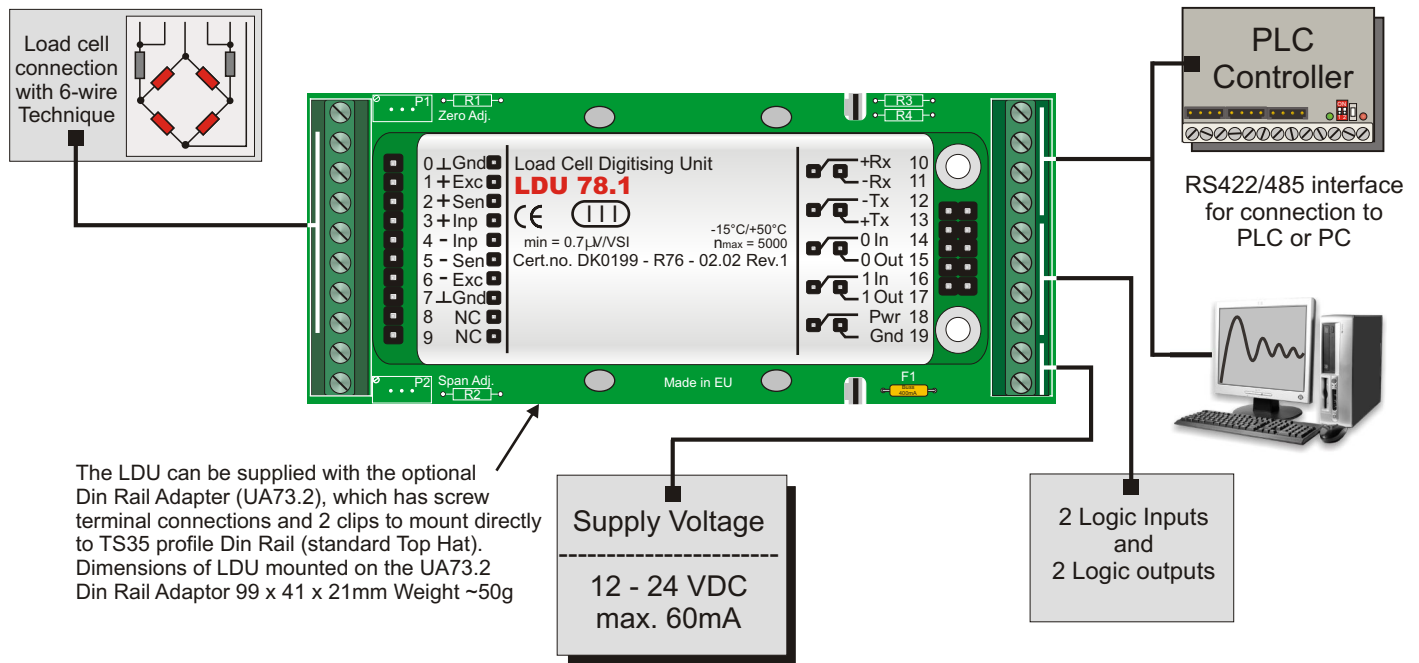

Specifications

All Dimensions in mm
Specifications are subject to change without prior notice

Linearity	: < 0.002 % of full scale
Load cell supply voltage	: 5 VDC, designed to drive one 250-2000 Ohm load cell
Input signal range	: +/-2,2 mV/V or +/- 11mVdc, with 6-wire technique
Input polarity	: Bipolar, for weighing, force and torque measurement applications
ADC resolution	: 18-Bit ADC ±260,000 divisions, Maximum output reading +/- 99.999 D
ADC conversion speed	: Up to 2400 measurements/sec. internal, maximum 600 measurements/sec transmitted.
Digital filter	: FIR filter 2.5Hz to 19.7Hz or IIR filter 0.25Hz to 18Hz each in 8 steps
Calibration	: Via ASCII protocol software commands
Communication interface	: RS-485 or RS-422 full duplex, 9600....115200 Baud, up to 32 devices on one bus.
Logic inputs	: 2 Inputs, 10-30VDC max. 3mA ref. to ground, status read via software interface
Logic outputs	: 2 Outputs open collector < 30VDC 0.2A ref. to ground.
Temperature effect	: <10ppm/°C on Zero and <8ppm/°C on Span
Temperature range	: -15°C to +50°C (working); -20°C to +60°C (storage)
Construction	: PCB with wrap around steel shield case sealed to IP40. Connector pins supplied but not fitted. Optional Din Rail Adaptor (UA73.2) available at extra cost.
Dimensions	: 82 x 31 x 6 mm, Weight ~ 30 g; with Adaptor 99 x 41 x 12 mm, ~50g
Power Supply	: 12...24 VDC +/-10 %, < 60mA, not galvanically isolated

D-LDU-78.1-5, 01/07