



### ***The Latest in the Scout® Line of Portable Balances – The Ohaus Scout Pro***

Designed for use in laboratory, industrial or education applications, the Ohaus Scout *Pro* continues the tradition set by the Ohaus Scout and Scout II products. Featuring easy-to-use two-button operation, a high-contrast LCD display, multiple weighing units, four application modes, and the option of either RS232 or USB connectivity, the Scout *Pro* is the portable balance for your needs.

- **Multiple Application Modes** – Including enhanced parts counting, percentage weighing, totalisation and display hold
- **Easy to Use** – The high-contrast LCD display combined with two key operation makes the ScoutPro easy to operate
- **USB or RS232 Connectivity** – Quickly-installed option with integral cable allows data connection to PC or printer
- **Easy to Clean** – Removable stainless steel weighing platform, sealed front panel and moulded spill ring.
- **Battery or AC Power** – Uses 4 "AA" batteries with auto shut-off feature for 40 hours of operation, or the Scout *Pro* can be run on the included AC powerpack
- **Multiple Weighing Units** – Including grams, kilograms, pounds, ounces, a combined pound:ounce display, troy ounces and pennyweights
- **Integral Weigh-Below Hook** – Critical for density or specific gravity determination

# Scout® Pro Portable Electronic Balances

## Built-In Application Modes:

**Parts Counting** – The Scout Pro is designed for counting parts for inventory control, parts bagging, receiving, dispensing and ticket counting

- Select from a sample size of 5, 10, 20 or 50 pieces while in counting mode with a quick button press
- The Scout Pro features user-enabled automatic recalculation of the average piece weight – instead of counting 100 parts for a sample, count 10 and let the Scout Pro count the rest of the sample. For applications where automatic recalculation is not desired, the easy-to-use menu system allows this feature to be disabled
- The Scout Pro can also be configured for situations where only the counting feature is required



**Percentage Weighing** – Use the *Percentage Weighing* mode to compare samples for compounding, formulation, or quick weight checking. Place your reference weight on the platform, enter the weight into memory, and the display will show the percentage of the sample weight on the platform compared to the reference weight.

**Totalisation** – Use the Scout Pro's memory function to repeatedly sum the weight on the platform for compounding and formulation. Unlike other balances the Scout Pro allows totalisation up to the limit of the display.

**Display Hold** – The *Display Hold* mode allows you to retain the weight of an over-sized package on the Scout Pro's display. Great for postal and shipping applications.

**User-Configurable** – The Scout Pro allows you to select active weighing units and modes using the two-button keypad. Scout Pro can be quickly configured using an on-display menu system – there are *no* cryptic codes to input. A built-in lockswitch prevents reconfiguration during use.

---

## New Design for Portable or Benchtop Use

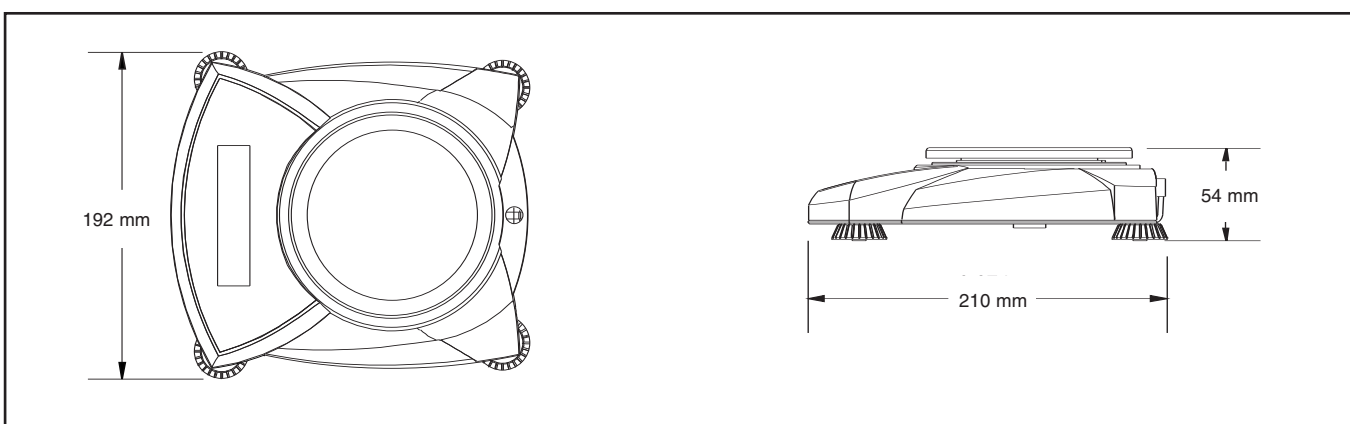

# Ohaus Scout Pro: Models for Every Application



**SPU601, SPU2001,  
SPU4001, SPU6001, SPU6000**



**SPU202, SPU402,  
SPU602, SPU401**



**SPU123**

- Parts Counting and Bagging
- Dynamic Weighing
- Feed Dispensing
- Medical Output Studies
- Crop and Seed Analysis
- Paint, Ink, Dye and Glaze Formulation
- Compound Preparation and Packaging
- Dental Adhesive and Compound Formulation
- Education Experiments
- Field Studies
- Parts Inventory, Quality Control and Receiving
- Filter Analysis
- Testing Kits
- Sample Gathering and Field Testing
- Food Portioning and Packaging
- Catering and Restaurant Applications
- Diet and Portion Control
- Jewellery Stores and Pawn Shops
- Injection Moulding Sampling
- Shipping and Receiving
- Ticket Counting

### Connectivity

An Ohaus first, you can quickly add either an internal RS232 or a USB port with integrated cable



### Security Bracket

Each Scout Pro features an integrated security bracket to prevent theft

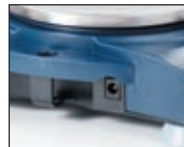

### Flexible Power

Use either the included AC adapter, or 4 "AA" batteries to power your Scout Pro

### Round or Square Stainless Steel Platform

Removable for easy cleaning

### Easy-to-Clean

Sealed front panel and moulded spill ring

### Easy-to-View

High-Contrast LCD quickly displays weight and applications data, as well as indicators for stability, over/underload conditions, and low battery power



### Lockswitch

The Scout Pro can be locked into a specific configuration using the included lockswitch

### Integral Shipping Lock

Quickly accessible under the weighing pan, the shipping lock allows you to lock and go



### Weigh Below Hook

The integral weigh-below-hook on the bottom of the Scout Pro allows density determination or calculating the specific gravity of samples



# Scout® Pro Portable Electronic Balances

## Specifications

Models	SPU123	SPU202	SPU402	SPU602	SPU401	SPU601	SPU2001	SPU4001	SPU6001	SPU6000
Capacity (g)	120*†	200	400	600	400	600	2000	4000	6000	6000
Readability (g)	0.001**	0.01		0.1						1
Repeatability (Std. Dev.) (g)	0.003	0.01		0.1						1
Linearity (g)	± 0.003	±0.01		±0.02	±0.1			±0.2	±1	
Weighing Units	g, oz, ozt, dwt				g, kg, oz, lb, lb:oz, ozt, dwt					
Application Modes	Parts Counting with Average Piece Weigh Recalculation, Percentage Weighing, Totalization, Display Hold									
Tare Range	To Capacity By Subtraction									
Over Range Capacity	Capacity +90d									
Stabilization Time	3 seconds									
Operating Temp. Range	10° to 40°C									
Power Requirements	AC Adapter (included) or 4 AA Batteries (not included)									
Calibration Type	Digital Calibration from Keypad									
Calibration Mass (Full Span)	100 g*	200 g*	400 g*	600 g*	400 g*	600 g*	2000 g	4000 g	6000 g	6000 g
Calibration Mass (Linear)	50 g	100 g	200 g	300 g	200 g	300 g	1000 g	2000 g	3000 g	3000 g
Display	High Contrast LCD with 6 digits 15mm high									
Pan Size (cm)	9 diameter	12 diameter				16.5 x 14.2				
Dimensions WxHxD (cm)	19.2 x 5.4 x 21.0									
Net Weight (kg)	0.7		0.8							
Shipping Dimensions WxHxD	25.4 x 10.2 x 30.5 cm									
Shipping Weight (kg)	1.8									

\* Calibration mass included

\*\* For results within ± 3mg repeatability

† Draughtshield included

## Standard Features/Equipment

Removable stainless steel weighing platform, high contrast LCD display, lockswitch, integral security bracket, integral shipping lock, integral weigh below hook, sealed front panel and moulded spill ring, stability indicator, overload and underload indicators, low battery indicator, auto shut-off, AC adapter, span calibration mass included on 200g, 400g and 600g models.

## Optional Accessories

RS232 Interface with 9-pin integral cable, USB Interface with integral cable, Toploading kit for Density determination, Security Device, SF42 Impact Printer, Converter for 9-pin to 25-pin RS232, Hard Shell Carrying Case, Sample Scoops and Calibration Masses.

## Industry Leading Quality and Support

All Ohaus Scout Pro balances are manufactured under an ISO 9001 Registered Quality Management System. Our rugged construction and stringent quality control have been hallmarks of all Ohaus products for nearly a century.

[www.ohaus.com](http://www.ohaus.com)

\* ISO 9001:2000  
Registered Quality Management System

80774011\_A © Copyright Ohaus Corporation

