



Pioneer™ Series

Analytical and Precision Balances



The Best Balance For Basic Weighing!

The OHAUS Pioneer™ Series of analytical and precision balances are designed for basic routine weighing in a variety of laboratory, industrial and education applications. With the right combination of performance and features, the OHAUS Pioneer offers uncomplicated performance for all your basic weighing needs.

Standard Features Include:

- **Easy to Clean Analytical Draftshield** – Pioneer's draftshield is designed with all glass panels, including three sliding doors. All panels are easy to remove and replace, and together with a stainless steel bottom, make it fast and easy to clean
- **Upfront Level Indicator** – Pioneer has been designed with an up-front level indicator, so that users can quickly ensure the balance is level prior to use
- **Selectable Environmental Settings** – Three filter modes and adjustable zero tracking adjust balance sensitivity to environmental disturbances, or application requirements
- **Flexibility of Available Options** – Ensure accuracy with the internal calibration option. Optional Approved models are available for compliance with legal requirements

Pioneer™ Analytical and Precision Balances

Removable Doors Provide Convenient Access and Easy Cleaning

To address the ease of cleaning requirement often expressed by routine users, Pioneer's draftshield has been designed with easy to remove doors and panels. Disassembly takes just seconds and all components including the balance housing can be quickly wiped clean.



Periodic cleaning made easy helps to avoid sample contamination and extends product life. In addition, a standard in-use cover provides added protection against accidental spillage and helps minimize the chance of damage to the display and keypad.



Should breakage occur, each replacement door or panel can be installed in seconds. A standard in-use cover provides added protection against accidental spillage.

Upfront Level Indicator Ensures Accuracy

The Pioneer has been designed with an up-front level indicator, eliminating the need to look behind the balance during the leveling process. A quick glance at the up-front level indicator helps you ensure that the balance is level prior to each use.



Selectable Environmental Settings For Working in Practically Any Condition

To help adapt the balance to real life working conditions, Pioneer is designed with selectable environmental settings. When working in harsh environments, the balance can be adjusted to compensate for vibrations and other disturbances. Conversely, the balance can be adjusted for working in slow filling applications where sensitivity is a must.

Added Flexibility of Available Options

To address accuracy concerns, the optional internal calibration allows the balance to be calibrated prior to use without the need of external weights. In addition, the optional OIML approved versions conforms to local requirements for balances used in legal applications.



Specifications

Models with Internal Calibration	PA64C	PA114C	PA214C	PA213C	PA413C	PA512C	PA2102C	PA4102C	PA4101C
Models without Internal Calibration	PA64	PA114	PA214	PA213	PA413	PA512	PA2102	PA4102	PA4101
Capacity (g)	65	110	210	210	410	510	2100	4100	4100
Repeatability (Std Dev) mg	0.1		1		10			100	
Readability d (g)	0.0001		0.001		0.01			0.1	
Linearity (mg)	0.2	0.3	2		20		30	100	
Application Modes	Weighing, Parts Counting, Percent								
Weighing Units	mg, g, ct, oz, dwt, tical, tola, mommes, baht, grain, mesghal, Newton, ozt, teals, custom				g, lb, ct, oz, dwt, tical, tola, mommes, baht, grain, mesghal, Newton, ozt, teals, custom		g, kg ct, lb, oz, dwt, tical, tola, mommes, baht, grain, mesghal, Newton, ozt, teals, custom		g, kg ct, lb, oz, dwt, tical, tola, mommes, baht, grain, mesghal, Newton, ozt, teals, custom
Platform Size (mm)	90 dia.		120 dia.		180 dia.				
Cal Weight-Span (g)	50g or 60g	50g or 100g	100g or 200g	100g or 200g	200g or 400g	200g or 500g	1kg or 2kg	2kg or 4kg	2kg or 4kg
Cal Weight-Linearity (g)	20g + 50g	50g + 100g	100g + 200g		200g + 400g	200g + 500g	1kg + 2kg	2kg + 4kg	
Taring Time	1 Second								
Stabilization Time	3 Seconds								
Gross Weight (kg)	4.5kg				3.3kg				
Shipping Weight (kg)	6.9kg				5.4kg				
Balance Dimensions W x H x D (cm)	19.6 x 28.7 x 32cm				19.6 x 9.2 x 32cm				
Carton Dimensions L x W x H (cm)	49.5 x 39.5 x 52.2cm				49.5 x 39.5 x 32.7cm				
Draftshield	Yes				None				
Operating Conditions	-10°C to 40°C at 10% to 80% relative humidity, non-condensing, up to 4000m above sea level								
Storage Temp.	-40°C to 70°C at 10% to 80% relative humidity, non-condensing.								

Specifications

Models with OIML Approval	PA64CM	PA114CM	PA214CM	PA213CM	PA413CM	PA512CM	PA2102CM	PA4102CM	PA4101CM
Capacity (g)	65	110	210	210	410	510	2100	4100	4100
Application Modes	Weighing								
Weighing Units	mg, kg, g, ct								
Verification scale interval e (mg)	1		10		100				

Outline Dimensions

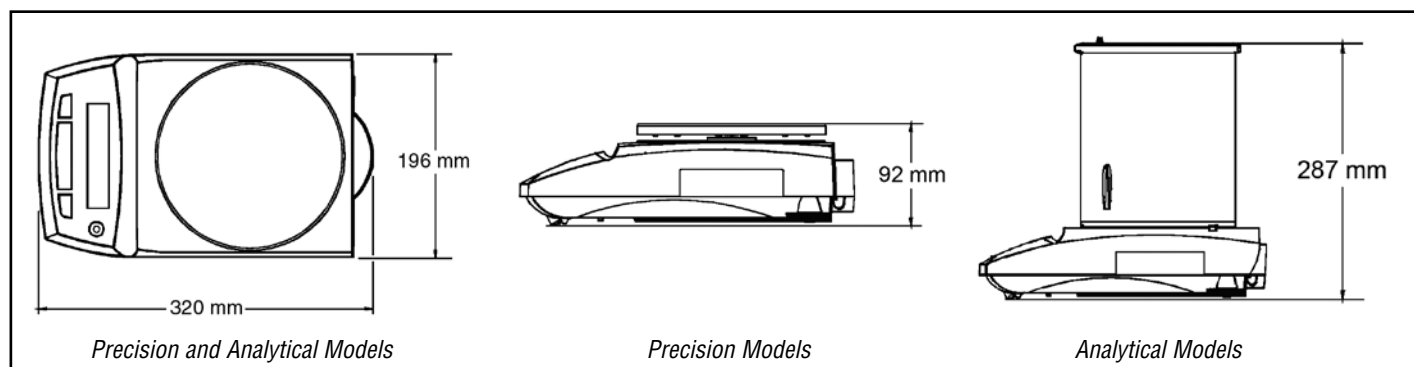

Pioneer™ Analytical and Precision Balances

Standard Features



Integral Security Bracket
Allows you to secure your balance to a workstation to prevent unwarranted movement or theft

RS232 Interface

Pioneer's RS232 allows connection to an Ohaus STP103, CBM910 printer or a computer. Sends Balance ID plus spaces for recording User ID, Project ID, time and date

Integral Menu Lock

A combination of software and a mechanical switch locks menus, including calibration

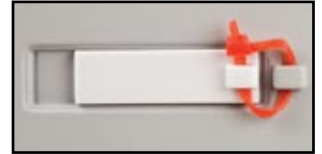

Weigh-Below Hook

Pioneer's built-in weigh-below hook allows you to suspend an item below the balance to calculate density/specific gravity



Up-Front Level Indicator

A quick glance at the up-front level indicator helps to ensure that the balance is level prior to each use

Multiple Application Modes and Units

Pioneer features basic Weighing, Parts Counting and Percent Weighing, and 19 international weighing units including one custom unit

Optional Internal Calibration

Allows the balance to be calibrated prior to use without the need of external weights

Other Standard Features and Equipment

AC adapter, user selectable span calibration points, software reset menu, stability indicator, Auto Tare, user selectable communications settings, user selectable printing options, stainless steel platform

Approvals

FCC
CE
C Tick N13123
OIML (optional)

Options and Accessories

	OHAUS Number
Internal Calibration.....	See Specification Table
OIML Approved Versions.....	See Specification Table
Secondary Display with backlight.....	80251396
Calibration Masses.....	Contact OHAUS for Full Offering
Security Device- Cable and Lock type	80850000
STP103 Thermal Printer - UK	80251194
STP103 Thermal Printer - EU	80251993
SRP275-GB Impact Printer.....	80251989
CBM910 Impact Printer - EU	80252043
RS232 cable, IBM 9 pin	00410024
RS232 cable, IBM 25 pin	80500524
OHAUS DAS Software	80253300

Industry Leading Quality and Support

All OHAUS Pioneer™ balances are manufactured under an ISO 9001:2008 Registered Quality Management System. Our rugged construction and stringent quality control have been hallmarks of all OHAUS products for over a century.

www.ohaus.com

* ISO 9001:2008
Registered Quality Management System

80774307_B © Copyright Ohaus Corporation

