

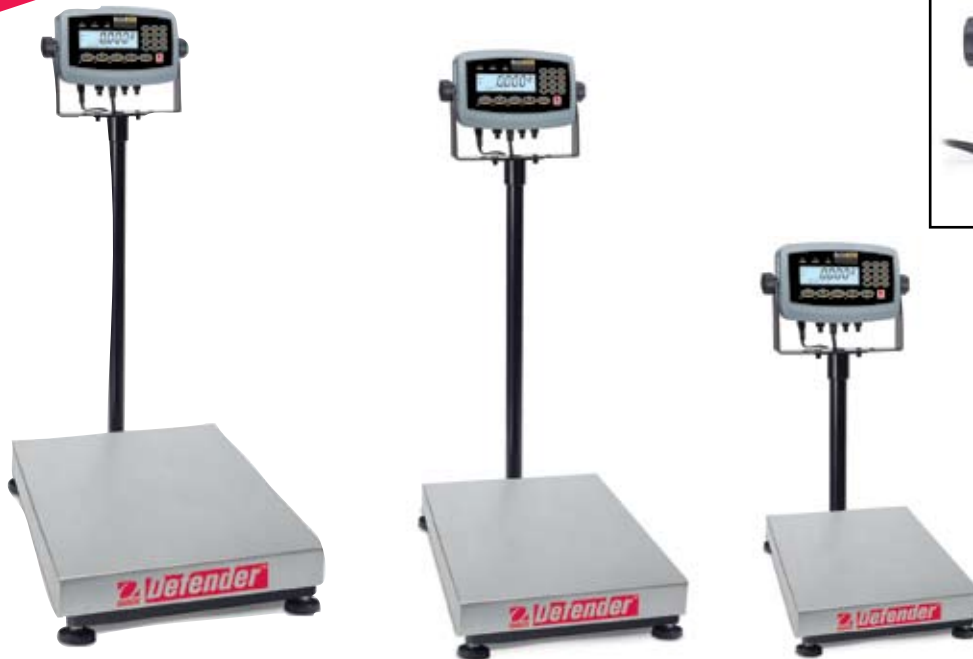

Defender™ 7000 Series

Advanced General Purpose Indicator, Bases and Bench Scales



Advanced Functionality, Durability, Ohaus Quality & Value

The OHAUS Defender™ 7000 Series is an advanced multifunctional line of indicators, bases and bench scales that is ideal for shipping and receiving, production, packing and general commercial, industrial and lab applications. Combining an ABS plastic T71P indicator with painted steel bases and columns, the Defender 7000 offers multi-functionality and multiple weighing units, alpha-numeric keypad and enhanced software modes. With rugged construction, comprehensive yet intuitive software, multiple connectivity, battery operation and configurable mounting, the Defender 7000 is a flexible one-stop solution for your demanding weighing operations.

Standard Features Include:

- ABS plastic indicator with resolutions up to 1:50000d/1:10000e and drives up to 8 x 350 load cells, bases with stainless steel pans, painted carbon steel frames and columns, OIML R60 approved IP67 aluminum load cells
- Scale displayed resolutions 1:12000-15000 (with temporary 10x high resolution display), approvable to 1:3000e, single and dual range operation
- Reversible rear housing for convenient orientation of cables, and flexible mounting (column and front mount) with angle-adjustable bracket
- Quick indication of results using large dual-line backlit LCD with high-contrast backlight, 3-color checkweigh LED with configurable setpoint beeper
- Multiple enhanced functionalities, such as: Counting, Percent, Dynamic, Display Hold, Checkweigh/count, Accumulation and Statistics, 256 Library Memory, Alpha-numeric Keypad, 5-language text display, GMP data output with time/date, Zero and 3-5 point Linearity Calibration, kg-g-lb-lb:oz-tonne-custom units
- Universal 110-230V power supply or 6 "C" batteries (80 hour operation), with optional NiMH internal rechargeable battery kit
- Built-in dual scale connection, RS232 interface and external input, with optional 2nd RS232, RS422/485, AC and DC relay kits
- Store, view and print over 262,000 date & time-stamped with the available Alibi memory kit

Defender™ 7000 *Advanced General Purpose*

Indicator Specifications

Model	751P
Construction	ABS plastic with internal reinforcing ribs, reversible rear housing, painted steel wall mount bracket with adjustment knobs
Full Scale Capacity Range	1 to 999,950 kg/lb
Max Displayed Resolution	1:50,000d
Maximum Approved Resolution	1:10,000e / Dual range 1:3000e
Maximum Counting Resolution	1:500,000d
Min Average Piece Weight (APW)	0.1d
Weighing Units	kg, lb, g, oz, lb:oz, tonnes, custom
Weight Display	2-line LCD with 6-digit, 7-segment, 25mm high primary digits, and high-contrast LED backlight
Checkweigh Indication	3-color LED with configurable beeper signal
Keyboard	17-key membrane switches (including alpha-numeric keypad), with positive tactile and audible feedback
Extra Functions/Modes	Dual range, Counting, Dynamic, Display Hold, Percent, Checkweighing/Count, Accumulation and Statistics, 256 Library memory, Five-language display
Other Software Features	Zero calibration, Calibration test, 5-point Linearity, Geographical gravity adjustment, Auto-tare, Auto-tare on-accept, GMP Time-Date, Key function lock, Temporary display of 10x resolution
Load Cell Excitation Voltage	5V DC
Load Cell Input Sensitivity	Up to 3 mV/V
Load Cell Drive	Up to 8 x 350 ohm load cells
Stabilization Time	Within 2 seconds
Zeroing Range	2% or 100% of capacity
Span Calibration	1 kg/lb to 100% of capacity
Interface	Built-in dual scale connection, RS232 and external input / Optional RS422/485 / AC relay / DC relay / second RS232 / Alibi memory
Operating Temperature Range	-10°C to 40°C
Relative Humidity Range	Maximum 80% up to 31°C, decreasing linearly to 50% at 40°C
Power	100-240 VAC / 50-60 Hz, internal universal power supply, line cord, 6 C-type dry cell batteries (80-hr. typical operation), optional internal rechargeable NiMH battery (30-hr. typical operation)
Enclosure Dimensions	260W x 71D x 168H mm
Overall Dimensions (inc. bracket)	316W x 71D x 224H mm
Net / Shipping Weight	1.5 kg / 2.3 kg
Shipping Dimensions	330W x 240D x 180H mm

Outline Dimensions

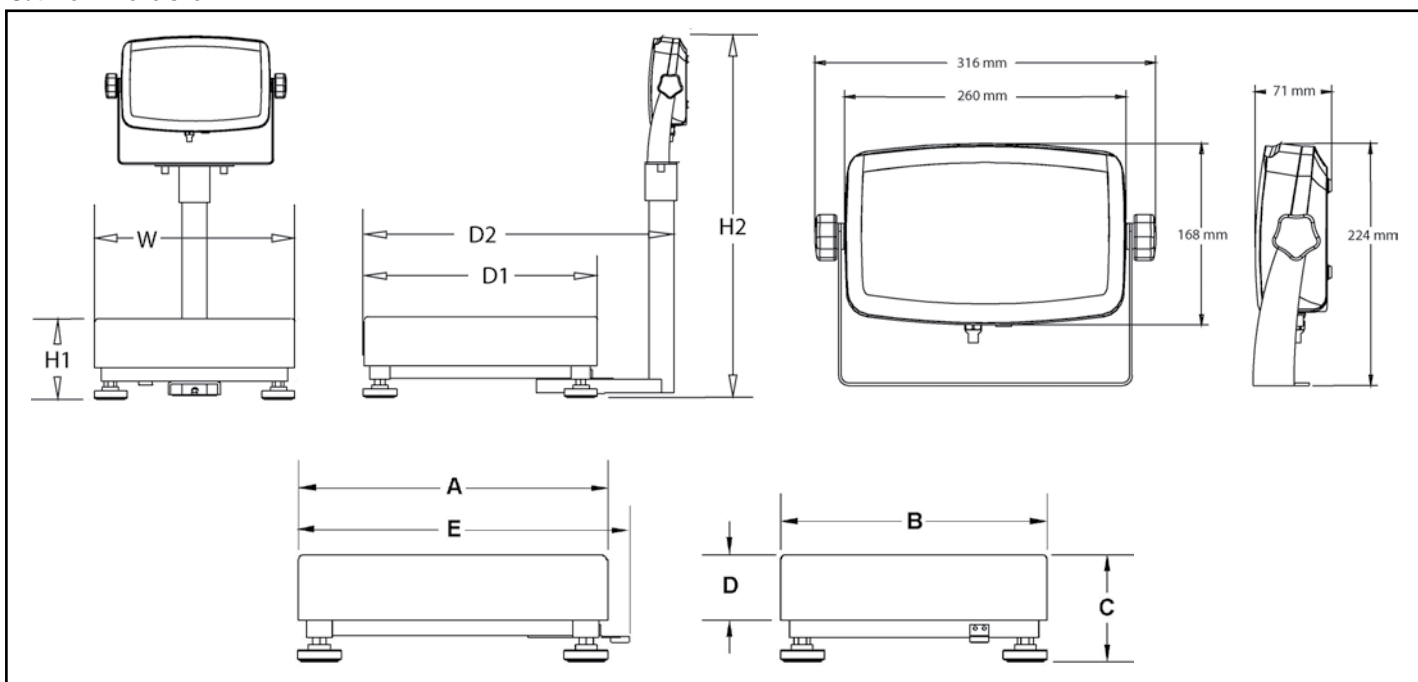

Purpose Indicator, Bases and Bench Scales

Standard Features

Simple Plug-In Battery Installation



Use six C-alkaline batteries or the optional NiMH battery

High-Visibility 2-Line Multi-Language LCD Display

with bright white LED backlight. Fast display stable weight within 2 seconds

Reversible Rear Housing

Cables can exit above (table or front scale mounting) or below (wall or bench scale mounting) for convenient mounting. Front scale mounting with available accessory. Internal structural ribs provide strength and minimize flexing.

3-Color LED Checkweigh Indication

with configurable beeper alert

Included Table/Wall Mount Bracket

With large ergonomic adjustable knobs to maximize viewing angles. A ratchet-type angle adjustment with a metal inserts ensures that viewing angles are set securely, and lasts long even with frequent adjustments



Alpha-numeric Keypad

Enhanced data entry of APW, weight settings and record ID's

Universal Switching Power Supply



100-240 VAC with AC line cord; no need for AC adapter!

One-Key, Multiple Mode Selection

Counting, Dynamic Weighing, Display Hold, Percent Weighing and Checkweighing

Stay Connected

Built in RS232 bi-directional, built-in external input, optional RS422/485, optional second RS232 and optional AC or DC relay

Painted Steel Columns

Available in both short and tall lengths with compatible base mounting, they offer flexible mounting possibilities.

Plug-in Load Cell Connector

Allows for simple connection to Defender bases or directly to terminal block. Available sealing collar for Type-approval applications



Fully Adjustable Feet

Four rugged, adjustable feet help prevent slippage on wet or uneven surfaces

Durable Base Frame Construction

Stainless steel pans and form-and-weld frames provide maximum durability, rigidity and structural integrity.

Load-unload cycle tested to ensure accurate long-term performance.



Options and Accessories

Interface Options	OHAUS Number
AC Relay Kit, T71P/T71XW.....	80500720
DC Relay Kit, T71P/T71XW.....	80500727
RS422/485 Interface Kit, T71P/T71XW	80500731
RS232 Interface Kit, T71P/T71XW.....	80500733
Foot Switch.....	71173378
Alibi Memory Kit, T71P/T71XW	80500503
<i>Power Options</i>	
Rechargeable Battery Kit, T71P/T71XW	80500729
<i>Approval Options</i>	
Load cell cable sealing collar, T71P	80500737
<i>Mounting Accessories</i>	
Wall Mount Kit, T71P	72200227
Wall Mount Kit, T71XW	80500735
Base Mount Kit, T71P	80500722

Mounting Accessories (continued)

	OHAUS Number
Column Mount Kit, 35cm, painted, T71	80500723
Column Mount Kit, 68cm, painted, T71	80500724
Column Mount Kit, 35cm, stainless steel, T71 ...	80500725
Column Mount Kit, 68cm, stainless steel, T71 ...	80500726

Compatible with all existing columns for Champs-CD/CW1/CD3X/CKW

Other Accessories

Load Cell Cable Adapter Kit.....	80500736
RS232 Cable, T31-71P to STP103 Printer	80252581
RS232 Cable, T31-71P to CBM910 Printer.....	80252571
RS232 Cable, T31-71P to SRP275 Printer.....	21253677
RS232 Cable, T31-71P to PC 25-pin.....	80500524
RS232 Cable, T31-71P to PC 9-pin.....	80500525
Printer STP103, 230VAC, EU Plug.....	80251993
Printer STP103, 230VAC, UK Plug	80251994
Printer CBM910, 230VAC, EU Plug	80252043
Printer SRP275, 230VAC, UK Plug	80251989

Defender™ 7000 *General Purpose Bench Scales*

Base Specifications

Base Model	D15QR	D15HR	D30QR	D30HR	D60HR	D60QL	D60HL	D150QL	D150HX	D300QX	D300HX
Capacity (Max)	15kg		30kg		60kg		150kg		300kg		
Construction	304 stainless steel pan, painted carbon steel frame, non-slip rubber leveling feet										
Leveling Components	Externally visible level bubble and adjustable leveling feet										
Operating Temperature	-10°C to 40°C										
Safe Overload Capacity	150% of rated capacity										
Load Cell Type	IP67, aluminum, single point / C3										
Load Cell Cable	2m L x 6-wire										
Load Cell Rated Output	2 mV/V ± 10%										
Load Cell Excitation Voltage	Maximum 20V (AC/DC) / Recommended 5~15V (AC/DC)										
Load Cell Input / Output Resistance	410 ± 10 ohms / 350 ± 4 ohms										
Base Dimension (AxBxCxDxE) (mm)	Q Series: H Series:	305 x 305 x 95 x 52 x 335 355 x 305 x 95 x 50 x 380				457 x 457 x 115 x 70 x 487 500 x 400 x 105 x 60 x 530		610 x 610 x 137 x 90 x 640 550 x 420 x 125 x 70 x 580			
Shipping Dimensions (mm)	Q Series: H Series:	490L x 410W x 440H 490L x 410W x 440H				810L x 600W x 240H 740L x 690W x 230H		1000L x 760W x 250H 750L x 710W x 230H			
Net / Shipping Weight	Q Series: H Series:	12.2 kg / 14.2 kg 9 kg / 11 kg				27.2 kg / 29 kg 19 kg / 22 kg		35 kg / 41 kg 24.5 kg / 27 kg			

Scale Specifications

Scale Model	D71P15QR1	D71P15HR1	D71P30QR1	D71P30HR1	D71P60HR1	D71P60QL2	D71P60HL2	D71P150QL2	D71P150HX2	D71P300QX2	D71P300HX2
Base Model	D15QR	D15HR	D30QR	D30HR	D60HR	D60QL	D60HL	D150QL	D150HX	D300QX	D300HX
Indicator Model	T71P										
Capacity x Max Readability (d)	15kg x 1g / 1:15000d		30kg x 2g / 1:15000d		60kg x 5g / 1:12000d		150kg x 10g / 1:15000d		300kg x 20g / 1:15000d		
Capacity x Approved Readability (e)	15kg x 5g / 1:3000e		30kg x 10g / 1:3000e		60kg x 20g / 1:3000e		150kg x 50g / 1:3000e		300kg x 100g / 1:3000e		
Column	350 mm fixed height, hollow tubular, painted steel					680 mm fixed height, hollow tubular, painted steel					
Scale Dimensions (WxH1xH2xD1xD2)	Q Series: H Series:	305 x 95 x 600 x 305 x 425 mm 305 x 95 x 600 x 355 x 475 mm				457 x 115 x 940 x 457 x 577 400 x 105 x 940 x 500 x 620		610 x 137 x 940 x 610 x 730 420 x 125 x 940 x 550 x 670			
Shipping Dimensions	Q Series: H Series:	490L x 410W x 440H mm 490L x 410W x 440H mm				810L x 600W x 240H mm 740L x 690W x 230H mm		1000L x 760W x 250H mm 750L x 710W x 230H mm			
Net / Shipping Weight	Q Series: H Series:	11.7kg / 14.1kg 11.9kg / 14.2kg				24.8kg / 27.7kg 23kg / 25.7kg		41.3kg / 44.7kg 28.3kg / 30.7kg			

Highlighted Features

- Counting (with negative sampling and counting, manual entry of APW, auto-optimization)
- Percent Weighing
- Dynamic/Animal Weighing/Display Hold (manual, semi-auto, auto)
- Checkweighing (with take-away checkweighing or checkcounting)
- Accumulation (manual or auto) with real-time view and printable statistics (no. of weighments, average, standard deviation, minimum, maximum, difference)
- Quick-recall library storage for up to 256 memory records for combination of different modes
- Alpha-numeric data and ID entries via keyboard
- Quick-key real-time display of reference data (such as APW, Setpoint limits, Statistics)
- Multi-language text displays (English, Spanish, French, German, Italian)
- GMP/GLP data output including data and time
- Calibration: Span, Zero, Calibration Test, 3 and 5-point Linearity
- Weighing units: kg, g, lb, oz, lb-oz, tonne, user-defined custom unit

Compliance

- **Safety and EMC:** EN60950, EN61326, FCC, CE, _CUL_{US}
Compliant to Directive 2002/96/EC on waste electrical and electronic equipment (WEEE)
- **Type Approval/Legal-for-Trade:**
 - T71xx Series Indicator: OIML R76/1992-NL1-09.17; TC7568R0 / T5980R6
 - Load Cells: OIML R60/2000-NL1-03.10 / TC5382; OIML R60/2000-NL1-03.14 / TC5367
- **Quality:** Ohaus quality management system registered to ISO 9001:2008

www.ohaus.com

* ISO 9001:2008
Registered Quality Management System

80774505 © Copyright Ohaus Corporation

