

Aluminum Single Point Load Cell



FEATURES

- Capacities 3 - 90kg
- Aluminum construction
- Single point 400 x 400mm platform
- NTEP approved
- IP65 protection
- Available with metric and UNC threads

OPTIONAL FEATURES

- EEx ia IIC T4 hazardous area approval
- FM approval available
- IP67 available

DESCRIPTION

Model 1010 is a single point load cell designed for direct mounting of low cost, low capacity weighing platforms.

Its use in large platforms, combined with its high accuracy and low cost, makes this load cell ideally suited for a large range of weighing applications, including bench scales and counting scales.

A special humidity resistant protective coating is available which ensures long-term reliability. For hazardous

environments this load cell has EEx ia IIC T4 level approved option.

Model 1010's built-in overload stop can provide mechanical protection against overloading.

The two additional sense wires feed back the voltage reaching the load cell. Complete compensation of changes in lead resistance due to temperature change and/or cable extension is achieved by feeding this voltage into the appropriate electronics.

APPLICATIONS

- Bench scales
- Counting scales
- Grocery scales

OUTLINE DIMENSIONS in mm

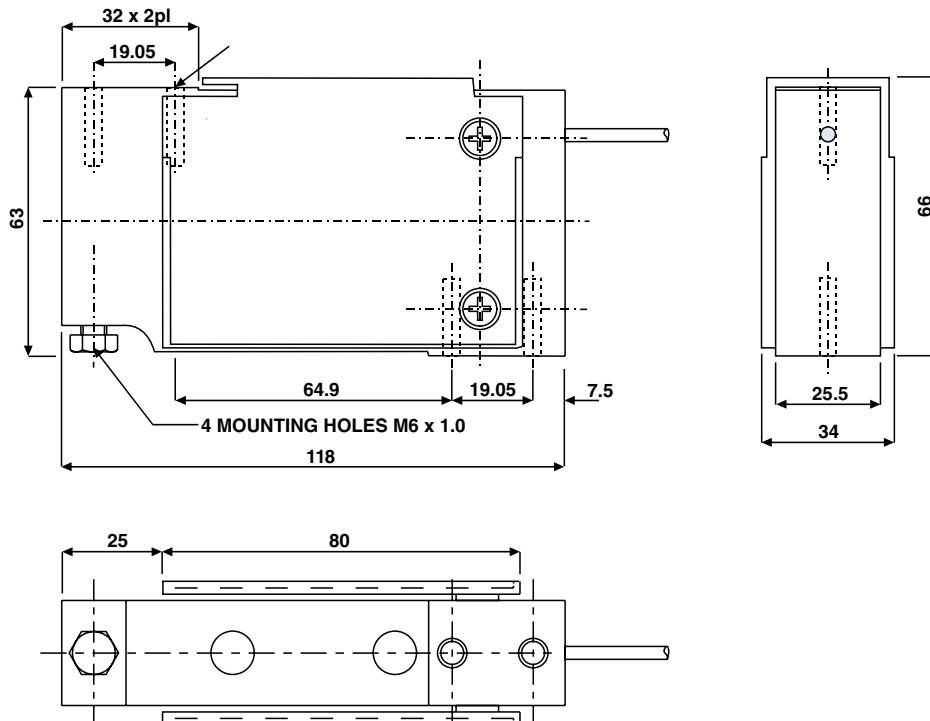

SPECIFICATIONS

PARAMETER	VALUE*		UNIT
Rated capacity-R.C. (E_{max})	3, 5, 7, 10, 15, 20, 30, 50, 90		kg
NTEP/OIML Accuracy class	NTEP	Non-Approved	
Maximum no. of intervals (n)	5000 single	3000	
$Y = E_{max}/V_{min}$	10000	10000	Maximum available
Rated output-R.O.	2.0		mV/V
Rated output tolerance	0.2		±mV/V
Zero balance	0.2		±mV/V
Zero Return, 30 min.	0.0330	0.0170	±% of applied load
Total Error (per OIML R60)	0.0200	0.0200	±% of rated output
Temperature effect on zero	0.0023	0.004	±% of rated output/°C
Temperature effect on output	0.001	0.0010	±% of applied load/°C
Eccentric loading error	0.0057	0.0074	±% of rated load/cm
Temperature range, compensated	-10 to +40		°C
Temperature range, safe	-20 to +70		°C
Maximum safe central overload	150		% of R.C.
Ultimate central overload	300		% of R.C.
Excitation, recommended	10		Vdc or Vac rms
Excitation, maximum	15		Vdc or Vac rms
Input impedance	415±15		Ohms
Output impedance	350±3		Ohms
Insulation resistance	>2000		Mega-Ohms
Cable length	1.0		m
Cable type	6 wire, PVC, single floating screen		Standard
Construction	Plated (Anodize) aluminum		
Environmental protection	IP65**		
Platform size (max)	400 x 400		mm
Recommended torque	Up to 30kg: 7.0 50kg & up: 10.0		N·m

* 1010 is non-balanced load cell (Non-balanced Bridge), 1015 is balanced

** IP67 available upon request

WIRING SCHEMATIC DIAGRAM (1010)
(unbalanced bridge configuration)

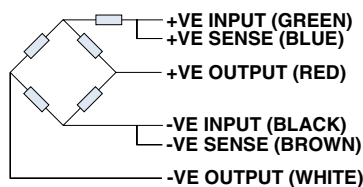

WIRING SCHEMATIC DIAGRAM (1015)

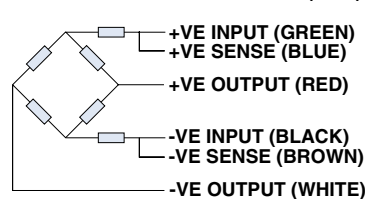

BALANCED TEMPERATURE COMPENSATION



Disclaimer

All product specifications and data are subject to change without notice.

Vishay Intertechnology, Inc., its affiliates, agents, and employees, and all persons acting on its or their behalf (collectively, "Vishay"), disclaim any and all liability for any errors, inaccuracies or incompleteness contained herein or in any other disclosure relating to any product.

Vishay disclaims any and all liability arising out of the use or application of any product described herein or of any information provided herein to the maximum extent permitted by law. The product specifications do not expand or otherwise modify Vishay's terms and conditions of purchase, including but not limited to the warranty expressed therein, which apply to these products.

No license, express or implied, by estoppel or otherwise, to any intellectual property rights is granted by this document or by any conduct of Vishay.

The products shown herein are not designed for use in medical, life-saving, or life-sustaining applications unless otherwise expressly indicated. Customers using or selling Vishay products not expressly indicated for use in such applications do so entirely at their own risk and agree to fully indemnify Vishay for any damages arising or resulting from such use or sale. Please contact authorized Vishay personnel to obtain written terms and conditions regarding products designed for such applications.

Product names and markings noted herein may be trademarks of their respective owners.