

## Stainless Steel Shear Beam Load Cell

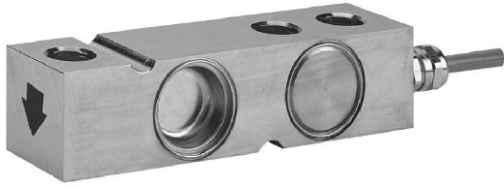

### FEATURES

- Capacities 300 - 5000kg, 1000 - 5000lbs
- Stainless steel construction
- OIML R60 and NTEP approved
- Hermetically sealed to IP68
- Specially designed for harsh environment

### OPTIONAL FEATURES

- EEx ia IIC T6 hazardous area approval
- FM approval available
- 1100Ω impedance available

### DESCRIPTION

Model 3510 provides the weighing industry with the ultimate protection necessary for today's hostile environments in an economical low profile range suitable for platform scale manufacture.

Its low profile and all welded sealing combined with high accuracy makes this load cell ideally suited for low profile platforms, pallet truck weighers, tanks and silos. The guide slots incorporated into the upper and lower mounting faces enable manufacturers to easily position the load cell.

Hermetically sealed against moisture, the construction of the model 3510 in combination with a polyurethane dual shielded cable, enables continuous operation in harsh environments while maintaining a high operating specification.

The two additional sense wires feed back the voltage reaching the load cell. Complete compensation of changes in lead resistance due to temperature change and/or cable extension, is achieved by feeding this voltage into the appropriate electronics.

### APPLICATIONS

- Low profile platforms
- Pallet truck weighing
- Tank and silo weighing
- Harsh environment weighing
- Food industry weighing

### OUTLINE DIMENSIONS in mm

**DIMENSIONS FOR CAPACITIES 300, 500, 1000 & 2000kg**

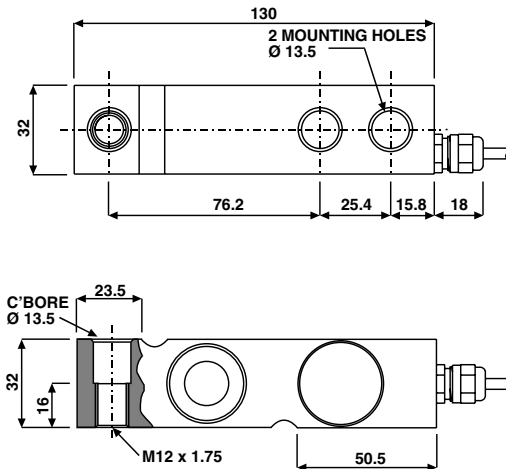

**DIMENSIONS FOR CAPACITY 3000kg**

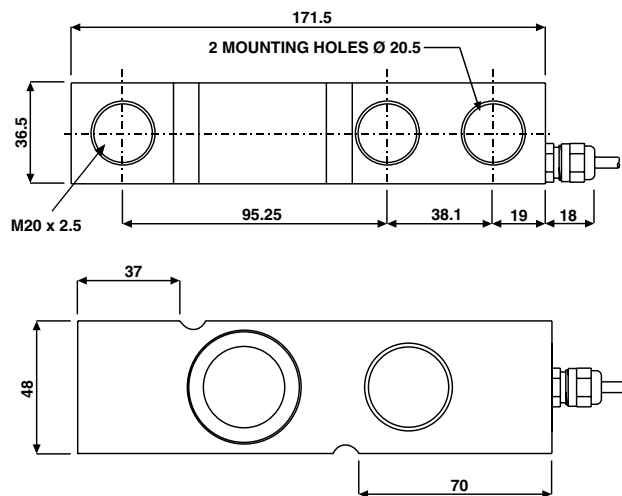

Standard end loading shown.

Options include:

- 'Through-hole' - plain or threaded.
- 'T-End' - supplied current and voltage matched for platforms.
- Imperial capacities can be manufactured with M12 or 1/2"-20 UNC threading

**SPECIFICATIONS**

PARAMETER	VALUE				UNIT
Rated capacity-R.C. ( $E_{max}$ )	300, 500, 750, 1000, 1200, 2000, 3000, 5000				kg
Rated capacity-R.C. ( $E_{max}$ )	1000, 1500, 2500, 4000				lbs
NTEP/OIML Accuracy class	NTEP	Non-Approved	C3	C6	
Maximum no. of intervals (n)	3000 single 5000 multiple	1000	3000*	6000**	
$Y = E_{max}/V_{min}$	12500	1400	6000	15000	Maximum available 20000
Rated output-R.O.	2.0 for kg and 3.0 for lbs				mV/V
Rated output tolerance	0.1				±% of rated output
Zero balance	2				±% of rated output
Zero Return, 30 min.	0.0250	0.0300	0.0170	0.0083	±% of applied load
Total Error	0.0200	0.0500	0.0200	0.0100	±% of rated output
Temperature effect on zero	0.0023	0.0100	0.0023	0.0009	±% of rated output/°C
Temperature effect on output	0.0010	0.0030	0.0010	0.00058	±% of applied load/°C
Temperature range, compensated	-10 to +40				°C
Temperature range, safe	-20 to +70				°C
Maximum safe central overload	150				% of R.C.
Ultimate central overload	300				% of R.C.
Excitation, recommended	10				Vdc or Vac rms
Excitation, maximum	15				Vdc or Vac rms
Input impedance	380±10				Ohm
Output impedance	350±3				Ohm
Insulation resistance	>2000				Mega-Ohm
Cable length	5				m
Cable type	6 wire, braided, Polyurethane, dual floating screen				Standard
Construction	Stainless steel				
Environmental protection	IP68				
Recommended torque	136.0 (3000 & 5000kg - 205.0)				N*m

\* 50% utilization

\*\* Capacities 300-1200kg, and 1000-2500lbs only

Wiring schematic diagram

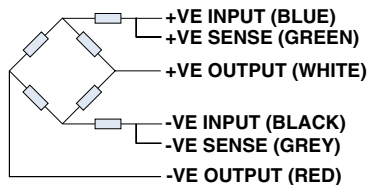



## Disclaimer

All product specifications and data are subject to change without notice.

Vishay Intertechnology, Inc., its affiliates, agents, and employees, and all persons acting on its or their behalf (collectively, "Vishay"), disclaim any and all liability for any errors, inaccuracies or incompleteness contained herein or in any other disclosure relating to any product.

Vishay disclaims any and all liability arising out of the use or application of any product described herein or of any information provided herein to the maximum extent permitted by law. The product specifications do not expand or otherwise modify Vishay's terms and conditions of purchase, including but not limited to the warranty expressed therein, which apply to these products.

No license, express or implied, by estoppel or otherwise, to any intellectual property rights is granted by this document or by any conduct of Vishay.

The products shown herein are not designed for use in medical, life-saving, or life-sustaining applications unless otherwise expressly indicated. Customers using or selling Vishay products not expressly indicated for use in such applications do so entirely at their own risk and agree to fully indemnify Vishay for any damages arising or resulting from such use or sale. Please contact authorized Vishay personnel to obtain written terms and conditions regarding products designed for such applications.

Product names and markings noted herein may be trademarks of their respective owners.