

Welded, Hermetically Sealed Load Cell



FEATURES

- Capacities 5 - 500kg
- Stainless steel construction
- OIML R60 and NTEP approved
- IP68 protection

OPTIONAL FEATURES

- EEx ia IIC T6 hazardous area approval
- FM approval available

DESCRIPTION

Model 355 is a welded bending load cell manufactured in stainless steel. Hermetically sealed against moisture the Model 355 construction and polyurethane shielded cable enables the load cell to function in harsh environments while maintaining its operating specifications.

The low profile, high accuracy and sealing makes this load cell highly suitable for applications such as low profile platforms, weighing and packing machines, conversion of mechanical scales and variety of other applications where sealed

cells are required. For hazardous environments this load cell is available with EEx ia IIC T6 level of approval as an option.

The two additional sense wires feed back the voltage reaching the load cell. Complete compensation of change in the lead resistance due to temperature change and/or cable extension, is achieved by feeding this voltage into the appropriate electronics.

APPLICATIONS

- Low profile platforms
- Loss-in-weight feeders
- Marine and hybrid scales
- Belt weighers
- Food industry harsh environment

OUTLINE DIMENSIONS in mm

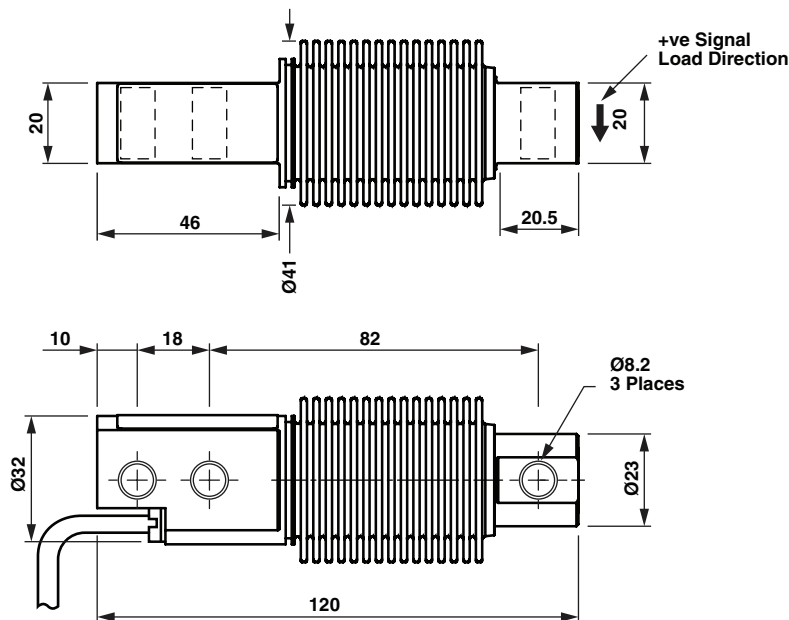

SPECIFICATIONS

PARAMETER	VALUE				UNIT
Rated capacity-R.C. (E_{max})	5, 10, 20, 30, 50, 100, 200, 250, 500				kg
NTEP/OIML Accuracy class	NTEP	Non-Approved	C3*	C4**	
Maximum no. of intervals (n)	4000 single	1000	3000	4000	
$Y = E_{max}/V_{min}$	5800	2000	15000	13333	Maximum available 15000
Rated output-R.O.	2.00 (UR matched 2.02)				mV/V
Rated output tolerance	0.002				±mV/V
Zero balance	0.2				±mV/V
Zero Return, 30 min.	0.0250	0.0500	0.0170	0.0130	±% of applied load
Total Error	0.0200	0.0300	0.0200	0.0150	±% of rated output
Temperature effect on zero	0.0023	0.007	0.0009	0.0011	±% of rated output/°C
Temperature effect on output	0.001	0.0040	0.0010	0.0008	±% of applied load/°C
Temperature range, compensated	-10 to +40				°C
Temperature range, safe	-20 to +70				°C
Maximum safe central overload	150				% of R.C.
Ultimate central overload	300				% of R.C.
Excitation, recommended	10				Vdc or Vac rms
Excitation, maximum	15				Vdc or Vac rms
Input impedance	380±10				Ohms
Output impedance	350±3				Ohms
Insulation resistance	>2000				Mega-Ohms
Cable length	3				m
Cable type	6 wire, braided, Polyurethane, dual floating screen				Standard
Construction	Stainless steel				
Environmental protection	IP68				
Recommended torque	22.0				N*m

* 20% utilization
 ** 30% utilization

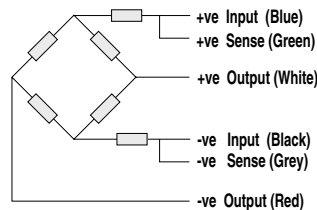
Wiring Schematic Diagram



Disclaimer

All product specifications and data are subject to change without notice.

Vishay Intertechnology, Inc., its affiliates, agents, and employees, and all persons acting on its or their behalf (collectively, "Vishay"), disclaim any and all liability for any errors, inaccuracies or incompleteness contained herein or in any other disclosure relating to any product.

Vishay disclaims any and all liability arising out of the use or application of any product described herein or of any information provided herein to the maximum extent permitted by law. The product specifications do not expand or otherwise modify Vishay's terms and conditions of purchase, including but not limited to the warranty expressed therein, which apply to these products.

No license, express or implied, by estoppel or otherwise, to any intellectual property rights is granted by this document or by any conduct of Vishay.

The products shown herein are not designed for use in medical, life-saving, or life-sustaining applications unless otherwise expressly indicated. Customers using or selling Vishay products not expressly indicated for use in such applications do so entirely at their own risk and agree to fully indemnify Vishay for any damages arising or resulting from such use or sale. Please contact authorized Vishay personnel to obtain written terms and conditions regarding products designed for such applications.

Product names and markings noted herein may be trademarks of their respective owners.