

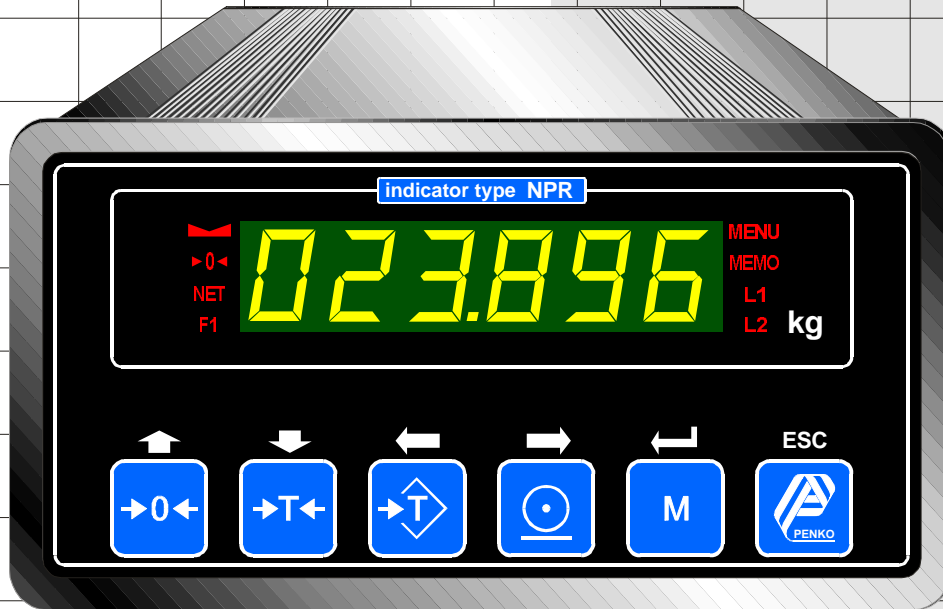

# Manual



## NPR Weigh indicator

Weigh Indicator type **NPR**

E-NPR

## **ESSENTIAL INSTRUCTIONS** **READ THIS PAGE BEFORE PROCEEDING!**

Penko Engineering, manufactures, and tests its products to meet many national and international standards. Because these instruments are sophisticated technical products, you must properly install, use, and maintain them to ensure they continue to operate within their normal specifications. The following instructions must be adhered to and integrated into your safety program when installing, using, and maintaining Penko products. Failure to follow the proper instructions may cause any of the following situations to occur: Loss of life; personal injury; property damage; damage to this instrument; and warranty invalidation.

- Read all instructions prior to installing, operating, and servicing the product. If this Instruction Manual is not the correct manual, telephone +31-318-525630 and the requested manual will be provided. Save this Instruction Manual for future use.
- If you do not understand any of the instructions, contact your Penko representative for clarification.
- Follow all warnings, cautions, and instructions marked on and supplied with the product.
- Inform and educate your personnel in the proper installation, operation, and maintenance of the product.
- Install your equipment as specified in the installation instructions of the appropriate Instruction Manual and per applicable local and national codes. Connect all products to the proper electrical sources.
- To ensure proper performance, use qualified personnel to install, operate, update, program, and maintain the product.
- When replacement parts are required, ensure that qualified people use replacement parts specified by Penko. Unauthorized parts and procedures can affect the product's performance and place the safe operation of your process at risk. Look alike substitutions may result in fire, electrical hazards, or improper operation.
- Ensure that all equipment doors are closed and protective covers are in place, except when maintenance is being performed by qualified persons, to prevent electrical shock and personal injury.

## **WARNING** **ELECTRICAL SHOCK HAZARD**

Making cable connections to and servicing this instrument require access to shock hazard level voltages which can cause death or serious injury.

Relay contacts made to separate power sources must be disconnected before servicing.

Electrical installation must be in accordance with the CE directions and/or any other applicable national or local codes.

Unused cable conduit entries must be securely sealed by non-flammable closures to provide enclosure integrity in compliance with personal safety and environmental protection requirements.

For safety and proper performance this instrument must be connected to a properly grounded three wire power source.

Proper relay use and configuration is the responsibility of the user.

Do not operate this instrument without front cover secured. Refer installation, operation and servicing to qualified personnel.

### **Penko Engineering b.v.**

Wageningsesteenweg 52-54

3903LA Veenendaal

The Netherlands

Tel ++(0)318-525630

Fax ++ (0)318-529715

e-mail: [info@penko.com](mailto:info@penko.com)

web-site: [www.penko.com](http://www.penko.com)

---

## Table of contents:

---

### ***NPR front explanation:***

Indication of LEDS	0-1
Explanation of front keys	0-1
Changing of code	0-2
Setpoint for outputs	0-2
Clock setting	0-2
Simplified basic block diagram	0-3

### ***Entering the setup menu:***

First use of the indicator	1-0
Set the indicator parameters Ind1-8	1-1
Set the Indicator parameters Ind9-10	1-2
Display filter settings Fil 1-3	1-2
Pre-calibration parameters PCL 1-2	1-2
Pre-calibration parameters PCL 3-5	1-3
Calibration Cal1-4	1-3
Short calibration method (see Cal1)	1-3
Calibration facilities of Cal1	1-4
Auto-range steps Rng 1-3	1-5
Communication baudrates bdr 1-2	1-5
Communication port protocols Port 1-2	1-6
Communication channel numbers Chn1-2	1-6
Clock settings CLo	1-6
Ticket layout settings Hdr 1-3	1-7
Ticket layout settings Hdr 4-8	1-8
Feature option CFG1	1-8
Setpoint mode setup	1-9
Setpoint action with hysteresis	1-9
Analog output settings	1-10
Recall the factory settings	1-10
Standard factory setting	1-11
Error codes explained	1-12

### ***Connections NPR:***

Connections of NPR Loadcell(s) & Communication ports RS232+422	2-1
Connections of NPR Analog & Digital in-/outputs	2-2
Dimensions and mounting	2-3

### ***Appendix:***

Appendix-A: Headers & Footers	3-1
-------------------------------	-----

## INDICATION OF LEDS.

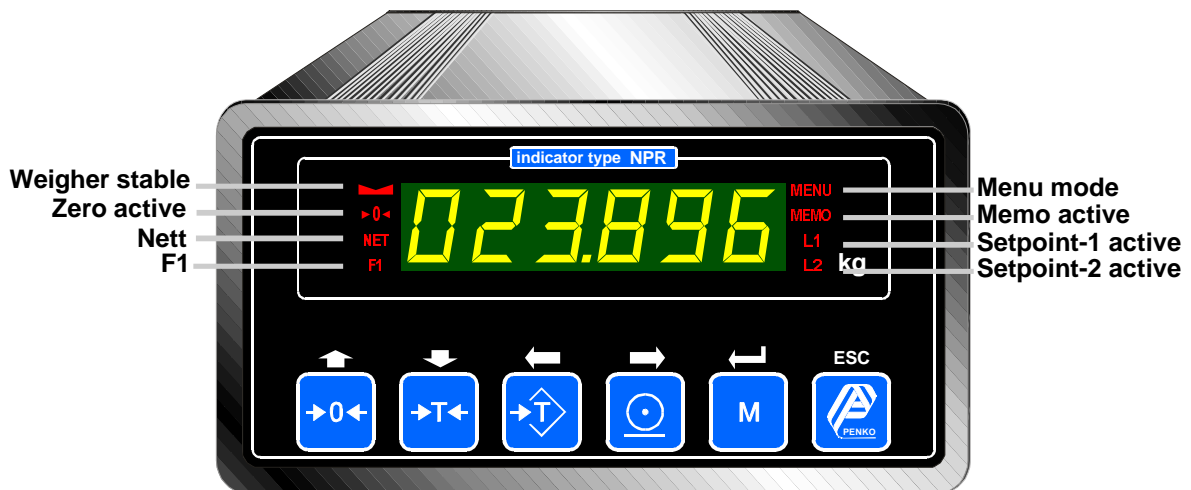

## EXPLANATION OF FRONT KEYS.

## Zero/UP key

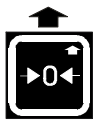

**CREATE A NEW ZERO LEVEL** Press key < 3 seconds.

**RESET OF INDICATOR.** Press at this key after starting up. The following settings will be reset: Preset codes, Presets of piece weighing, Setpoint values & Preset tare values.

## Tare/DOWN key



**TARE ON OR OFF.** Look to the Nett sign if there's a tare active.

**Short calibration method for 2 points calibration.** When starting up the indicator press this key and make a calibration of 2 points. **Note!** All existing calibration points will be overwritten.

## Preset Tare/LEFT key

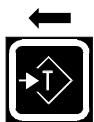

**PRESET TARE VALUE.**

Press the Preset Tare key, change the value or select a stored value and confirm with ENTER.

There can be **10** preset tares in memory. After pressing Preset Tare the first dot is blinking of the led bar. Select a value with the UP or DOWN key. Confirm the selected value with ENTER.

**Changing a preset tare value:** Press the Preset Tare key. Select a value with UP or DOWN. Press the LEFT key to start changing the value. Confirm the value with ENTER.

## Print/RIGHT key

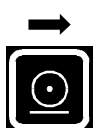

**PRINTING ACTUAL, TOTAL VALUE or DAY VALUE.**

Press under <3s to print the actual weight

Press longer >3s to view the current total. Press the PRINT key again to print and reset the total value.

Note: It's also possible to print a day total. When viewing the current total press the LEFT key to toggle between total and day total. When displaying day total, the MEMO led blinks. Pressing the PRINT key will print the selected total and reset.

## EXPLANATION OF FRONT KEYS.

## Memory/ENTER key

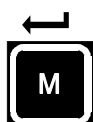
**CHANGING OF CODE, SETPOINT & CLOCK.**

Pressing this key enters the user menu. Press the UP or DOWN key to select one of the menu options (<--Code>, <--SEtP> or <---Clo> and press ENTER.

**CHANGING OF CODE.**

The code is a value which will be printed on the ticket when printing is enabled. There can be **10** code presets in memory.

**Select a preset code:** After selecting the CODE menu press ENTER. The first dot of the led bar is blinking. Choose a CODE with the UP or DOWN key and confirm with ENTER. If you leave the menu with the ESC key the display shows oFF and the code will not be printed.

**Changing/Setting of codes:** First select a code with UP or DOWN. Press at the LEFT key and change the CODE. Confirm the value with code.

**SETPOINT FOR OUTPUTS.**

With this function you can set new and select existing values for the outputs. Up to **10** setpoint values can be stored in memory.

**Selecting a preset SETPOINT value.**

First select the setpoint menu (<--SEtP>). Then press at ENTER. The first value is for setpoint-1. Choose a preset SETPOINT value for setpoint-1 with the UP or DOWN key. Confirm this value with ENTER. Automatically the indicator comes with the value for setpoint-2. Choose a value for setpoint-1 with the UP or DOWN key. Confirm this value with ENTER. Now the weigher comes back in the weigher mode.

**Changing or Adding of preset SETPOINT values**

First select the setpoint menu (<--SEtP>). Then press at ENTER. The first value is for setpoint-1. When you have less then 10 preset SETPOINT values you can give in a new value with the LEFT, UP and DOWN keys. This value will be stored as a new preset value. When you already have 10 points stored in memory then first select a value with the UP and DOWN keys. Then change this value and it will be overwritten. Automatically the indicator comes with the value for setpoint-2. Follow the described notes as wirtten here above. After changing or adding the weigher comes back in the weigher mode.

The settings for both setpoints must be made at the <---Fun> and <---Acn> menu.

**CLOCK SETTING (DATE & TIME).**

With this function you can change the date and time. First select the CLOCK menu (<--CLo>).

Then press ENTER. First you can change the date (dd.mm.yy). Confirm the date with ENTER. Then you can change the time. Confirm the time with ENTER.

## PENKO/ESC key

**ON-OFF/ESC key**

Use this key to escape from the actual function\menu.

This block diagram is an explanation of how the digital indicator works. After the amplifier the signal goes through an overall digital filter. This filter influence all the following values of the instrument. With the zero system you control the zero point of the connected weighing installation. The linearize function allows you to correct some repeatable non linearity. The limited range damping is a power full system. It shortens the time you need for getting a ready value. A tare system is available. For the display value exist, beside power full software tools a zero suppressing system.

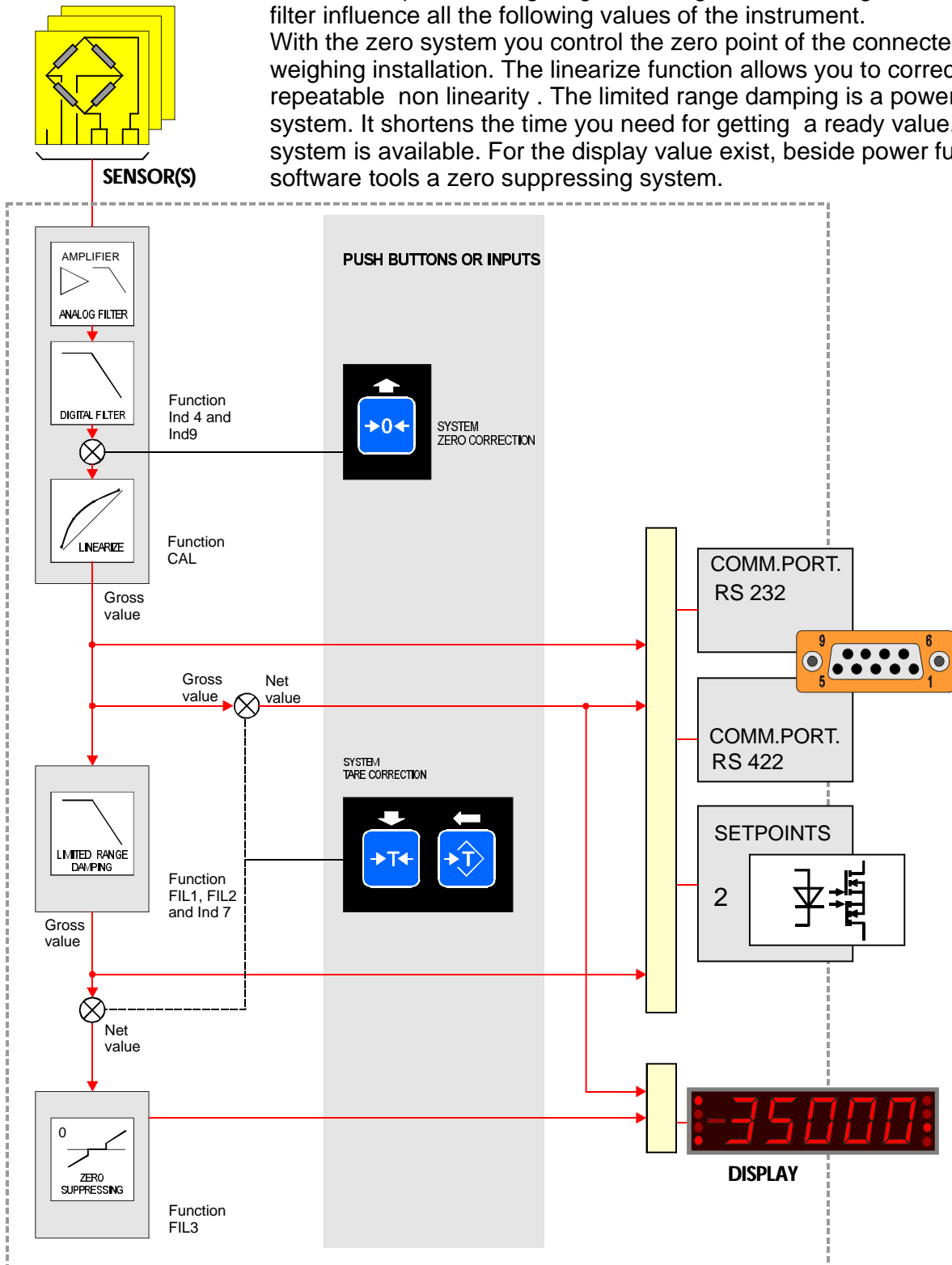

The block diagram shows the real power of the instrument. You are free to connect each value, gross value, nett value, gross extra filtered value or nett extra filtered value, to one of the output devices. The configuration is separate for each output. Outputs are: Communication port RS232 and RS422 and set points. The tare system and the zero suppressing tool is connected to the display.

## FIRST USE OF THE INDICATOR: NPR

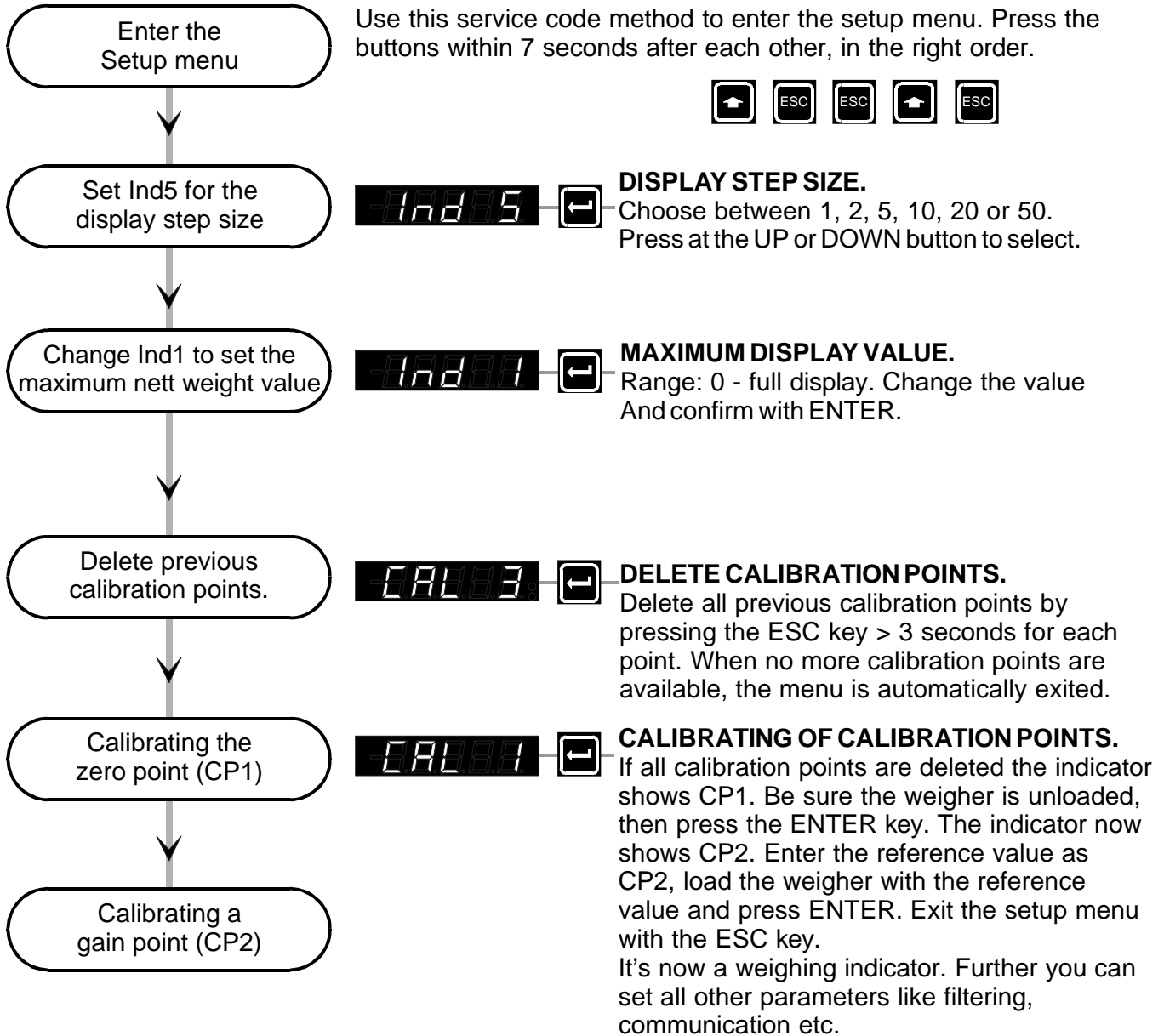

# ENTERING THE SETUP MENU

INDICATOR: NPR

Use this service code method to enter the setup menu. Press the buttons within 7 seconds after each other, in the right order.



## ---Ind SET THE INDICATOR PARAMETERS

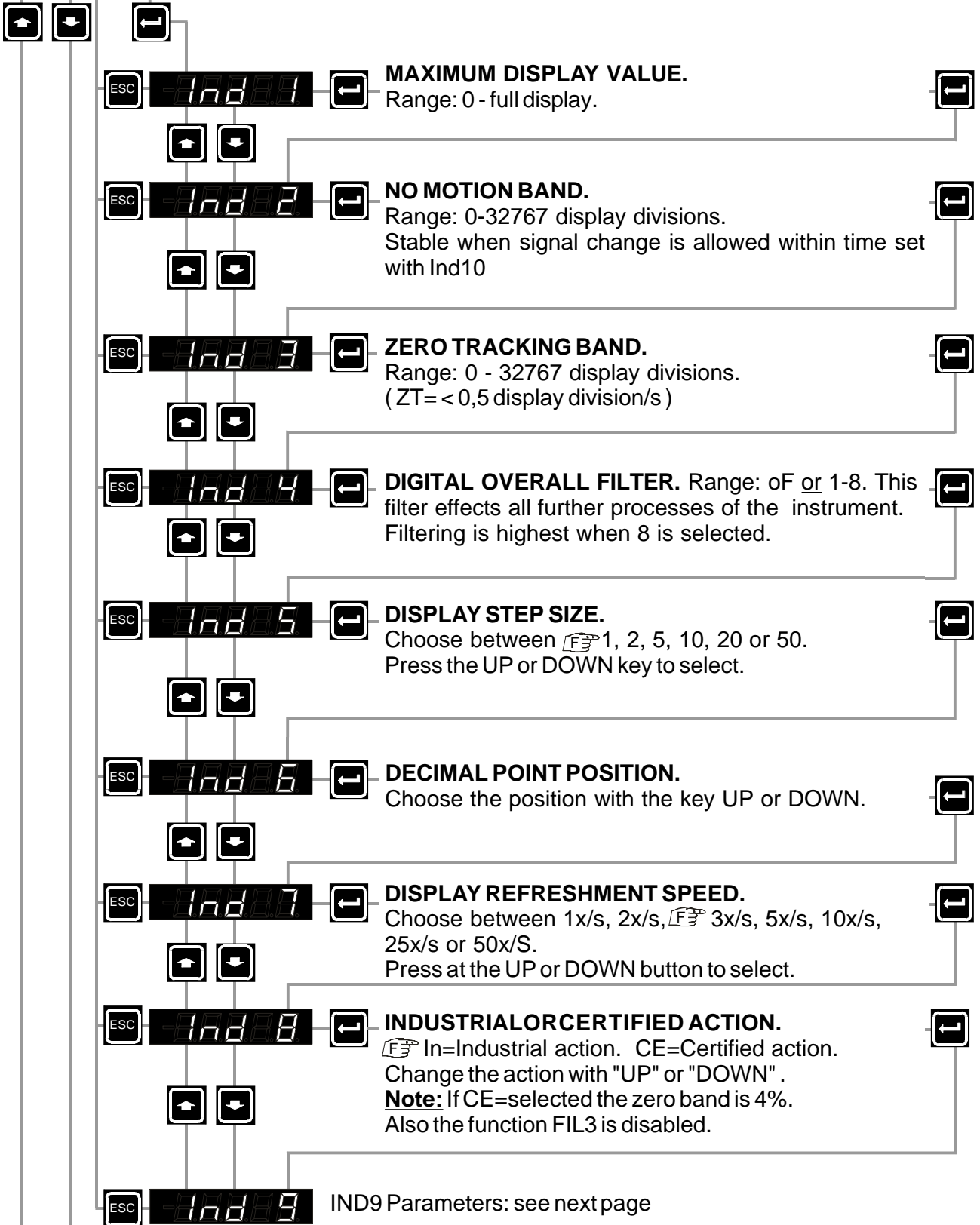

## ---FIL FILTER SETTINGS: see next page.



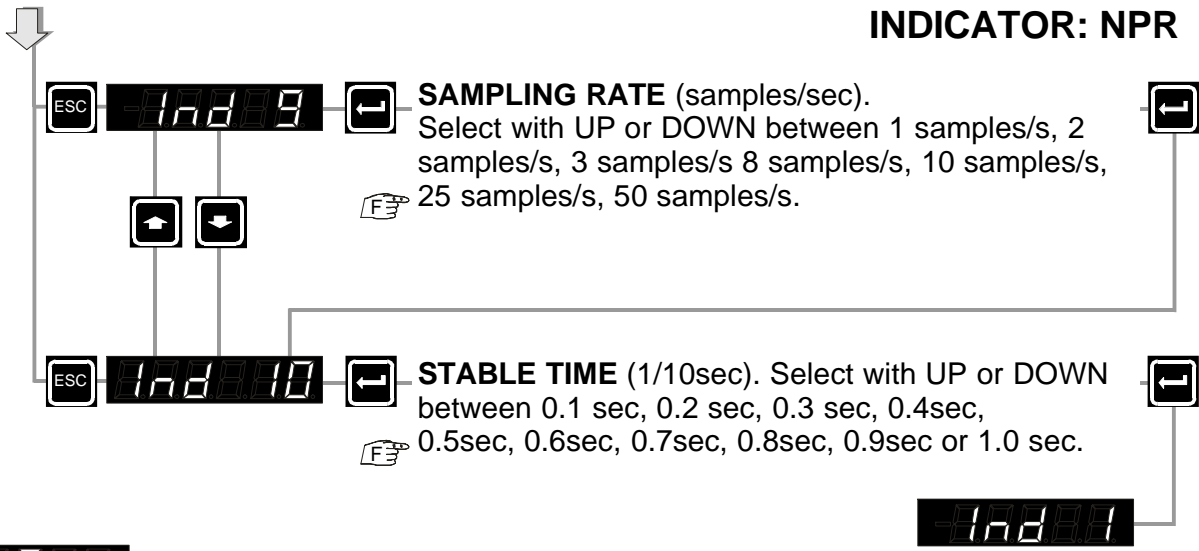

**DISPLAY FILTER SETTINGS**

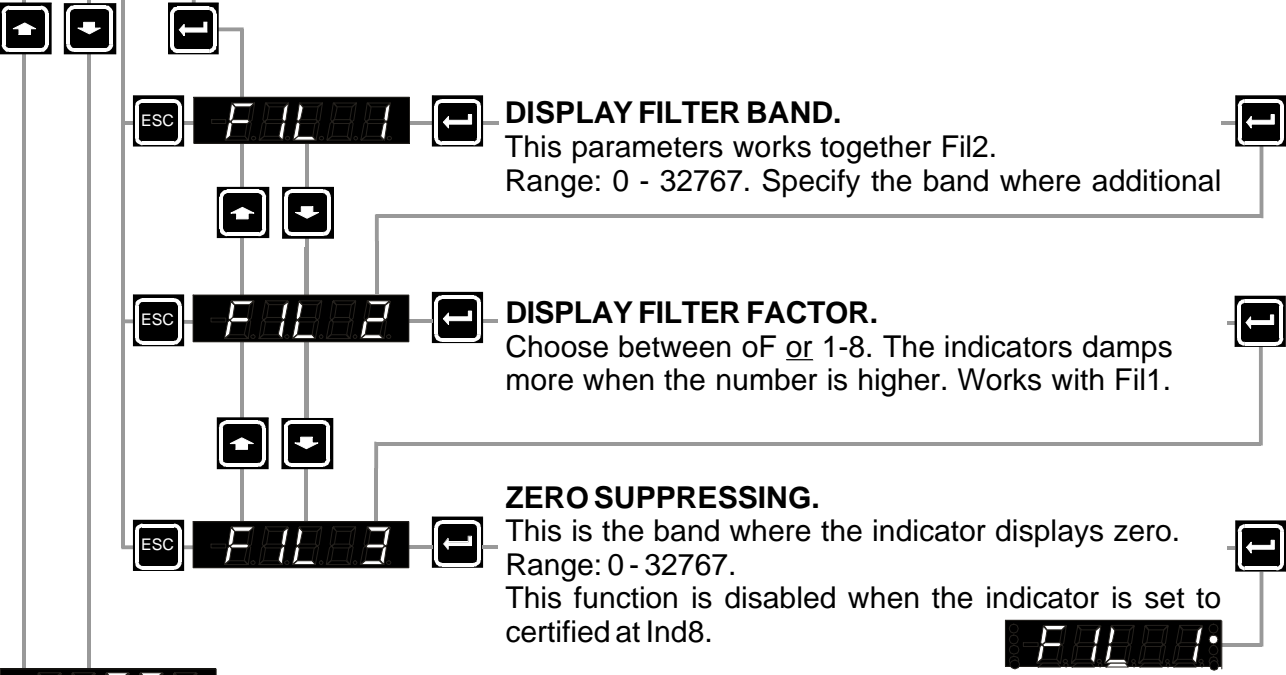

**Pre-CALIBRATION PARAMETERS.**

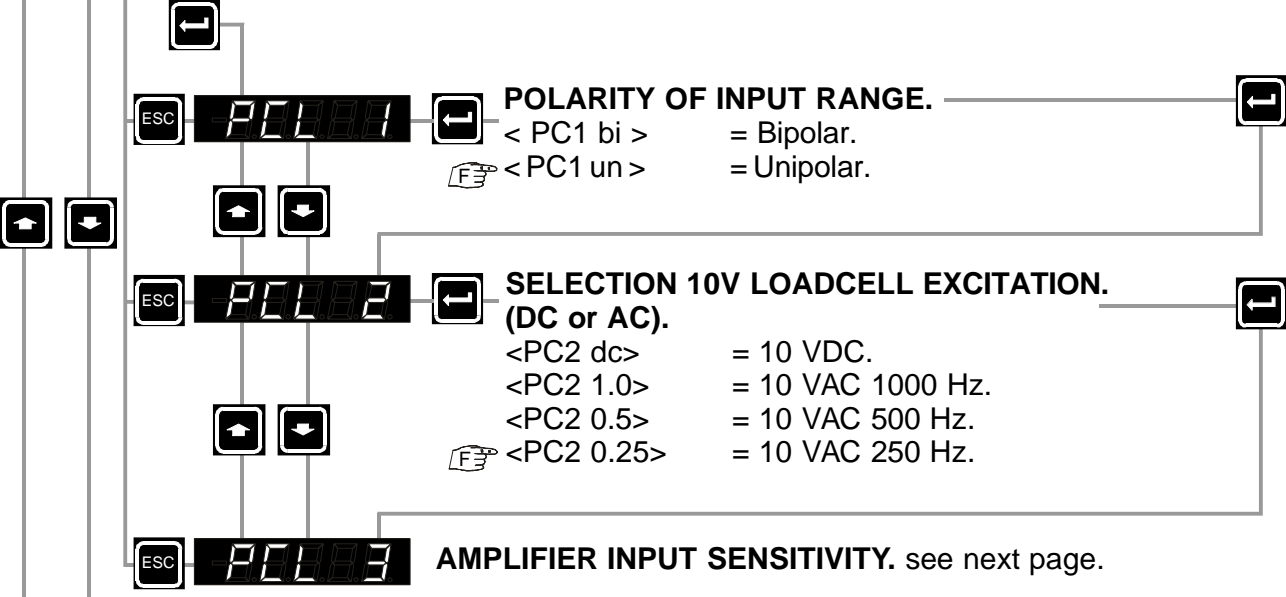

**CALIBRATION FACILITIES:** see next page.



**PCL 3** **AMPLIFIER INPUT SENSITIVITY.**

Range: 0,5-3,5mV/V

- < PC3 0,5> = 0,5 mV/V
- < PC3 1.0> = 1,0 mV/V
- < PC3 1.5> = 1,5 mV/V
- < PC3 2.0> = 2,0 mV/V
- < PC3 2.5> = 2,5 mV/V
- < PC3 3.0> = 3,0 mV/V
- < PC3 3.5> = 3,5 mV/V

**PCL 4** **CHANGE ADC OFFSET (DEAD LOAD COMPENSATION)**

Change value with UP & DOWN.  
Minimum = 0 / Maximum = 65535.  
Press the Left-key >3 sec for searching a preset value:  
After pressing the LEFT key >3sec the indicators shows "SEArCH" and then it goes searching the new ADC level. Unipolar level = about 5000 ADC-parts. Bipolar level = about 32700 ADC-parts.

**PCL 5** **RECALL THE PRECALIBRATION SETTINGS.**

The indicator shows "rEcALL".  
Press at "ESC" >3 sec.  
Standard settings: PCL1=Unipolar, PCL2=10VAC 250Hz, PCL3=2mV/V, PCL4=about 5000

**--CAL**

**CAL 1** **CALIBRATING: SEE NEXT PAGE.**

**CAL 2** **TOGGLE BETWEEN TRACKING- & ADC- VALUE.**

Use the LEFT key to toggle between analog & weight value. Press the ZERO key for display value

**CAL 3** **CHECK AND DELETE CALIBRATION POINTS.**

Step through the calibration points with the "UP" and "DOWN" key.  
You can watch the calibration points (weight) (x10) or the ADC value (ADC value during the calibration) by pressing the LEFT key.  
Delete a calibration point by pressing the ESC key >3 seconds.

**CAL 4** **FIX CALIBRATION.**

The display shows <-CA4->. Press the "LEFT" key <seconds. Set the current value with the keys (for example ZERO and confirm with ENTER.

**CAL 5** **VIEW TRACEABLE ACCESS CODE.**

The code is number of times that you have entered one of the following menu's: Ind1, Ind2, Ind3, Ind5, Ind6, Cal1, Cal3 or rEcALL. The code is necessary for checking when Ind8 is selected as certified.

**---PAG**

AUTO RANGE SETTINGS: see next page.



**CALIBRATION FACILITIES**

**DELETE THE EXISTING CALIBRATION POINTS FIRST.**

(Set by the factory, so it was already a working instrument.)

**USE < CAL 3 > TO DELETE EXISTING CALIBRATION POINTS.**



CALIBRATING THE INSTRUMENT.



SET " VALUE CALIBRATION POINT -1- ". CHANGE THE VALUE WITH THE KEYS: UP, DOWN, LEFT, RIGHT.

LOAD THE STRAIN GAUGE TRANSDUCER EQUAL TO THE CALIBRATION VALUE



SET " VALUE CALIBRATION POINT -2- ". CHANGE THE VALUE WITH THE KEYS.

LOAD THE STRAIN GAUGE TRANSDUCER EQUAL TO THE CALIBRATION VALUE



FOR EXAMPLE CP3



ADD NEW POINTS. WHEN CAL. POINT 1 & 2 EXISTS THE DISPLAY SHOWS < -CP3-->. WHEN ALSO CAL. POINT 4 EXISTS THE DISPLAY SHOWS 5 etc.etc.

SET " VALUE CALIBRATION POINT -3- ". CHANGE THE VALUE WITH THE KEYS.

LOAD THE STRAIN GAUGE TRANSDUCER EQUAL TO THE CALIBRATION VALUE



BLINKING



WHEN 10 CAL.POINTS EXISTS THE DISPLAY SHOWS <Error>. PRESS AT ESC AND DELETE A POINT WITH CAL3.



SEE NEXT PAGE.





**AUTO RANGE STEP CONFIGURATION.**



**SET THE NUMBER OF DISPLAY DIVISIONS.**

This is the number of divisions when the indicator has to display with the active step size. Autorange always start with the step size of the indicator (ind5).

Example: The normal step size is per 1 (ind5 =1), Rng1=100 and Rng2=50.

Indicator display	Step size per
0-100	1
100-200	2
200-500	5
500-1000	10
1000-2000	20
2000-5000+	50

Auto ranging is disabled when range size is set to 0. The biggest step size must be set in rnG 2. The maximum preset tare only works, and this is also the biggest value, to the first level of the autorange when the indicator is set to certified in Ind8. In this example the preset tare is valid to 100.

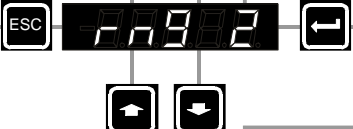

**MAXIMUM AUTO RANGE STEP SIZE.**

This is the maximum step size which the indicator will use. The step sizes are 1, 2, 5, 10, 20 & 50.



**AUTO RANGE RESET OPTION.**

Auto ranging can be reset either when entering a lower range or returns to zero.

- <rn3 oF> = reset Auto Range on zero level.
- <rn3 on> = reset Auto Range in lower range.



**COMMUNICATION BAUDRATES.**



**BAUDRATE SETTING FOR COMPORT-1 (RS422).**

- < bd 110 > = 110 baud
- < bd 150 > = 150 baud
- < bd 300 > = 300 baud
- < bd 600 > = 600 baud
- < bd 1.2 > = 1200 baud
- < bd 2.4 > = 2400 baud
- < bd 4.8 > = 4800 baud
- < bd 9.6 > = 9600 baud
- < bd 19.2 > = 19200 baud
- < bd 38.4 > = 38400 baud
- < bd 57.6 > = 57600 baud
- < bd 115.2 > = 115200 baud



**BAUDRATE SETTING FOR COMPORT-2 (RS232).**

- < bd 110 > = 110 baud
- < bd 150 > = 150 baud
- < bd 300 > = 300 baud
- < bd 600 > = 600 baud
- < bd 1.2 > = 1200 baud
- < bd 2.4 > = 2400 baud
- < bd 4.8 > = 4800 baud
- < bd 9.6 > = 9600 baud
- < bd 19.2 > = 19200 baud
- < bd 38.4 > = 38400 baud
- < bd 57.6 > = 57600 baud
- < bd 115.2 > = 115200 baud



PORT COMMUNICATION PROTOCOL: see next page.



--Port

PORT COMMUNICATION PROTOCOL

COMMUNICATION PROTOCOL FOR COMPORT-1.

Comport-1 = RS422

- < Pt1 oF > = no protocol used.
- < Pt1 PC > = PenkoPCascii-protocol(SeeAppendix).
- < Pt1 PU > = PenkoPVprotocol.
- < Pt1 PR > = forprintingoutput.
- < Pt1 Pt > = two phase protocol

(Pt protocol is only applicable for Penko)  
**Note:** It's not possible to select the same protocol for both comports.

COMMUNICATION PROTOCOL FOR COMPORT-2.

Comport-2=RS232

- < Pt2 oF > = no protocol used.
- < Pt2 PC > = PenkoPCprotocol(SeeAppendix).
- < Pt2 PU > = PenkoPVprotocol.
- < Pt2 PR > = forprintingoutput.
- < Pt2 PT > = two phase protocol

(Pt protocol is only applicable for Penko)  
**Note:** It's not possible to select the same protocol for both comports.

bdr 1

--Chn

COMMUNICATION CHANNEL NUMBER FOR COMPORTS.

SELECT CHANNEL NUMBER FOR COMPORT-1.

Give in a number for comport-1.

**Note:** First select a protocol for comport-1 in the Port1 menu.

PC protocol: Chn0 is always open.

Chn255 results at continuous display output.

PV protocol: Chn0 is auto transmit.

SELECT CHANNEL NUMBER FOR COMPORT-2.

Give in a number for comport-2.

**Note:** First select a protocol for comport-2 in the Port2 menu.

PC protocol: Chn0 is always open.

Chn255 results at continuous display output.

PV protocol: Chn0 is auto transmit.

Port 1

--Clb

CLOCK SETTING (DATE & TIME).

ESC 01.09.97

Change the date with the keys (dd.mm.yy.)

ESC 13.28.07

Change the time with the keys (hh.mm.ss.)

--Prn

--Prn

TICKET LAYOUT SETTINGS: see next page.



--Prn

TICKET LAYOUT SETTINGS

Note: Printer protocol must be selected in Port menu

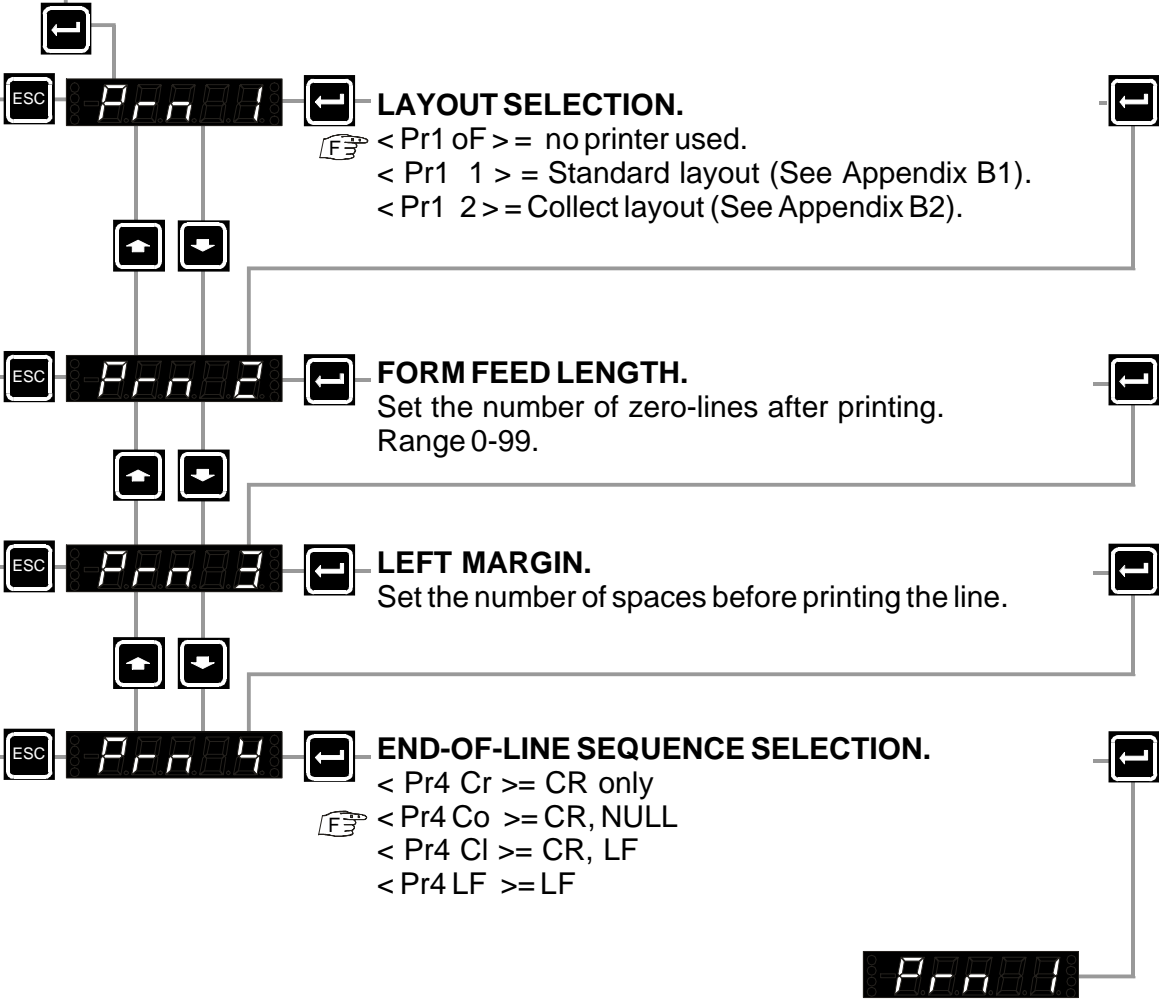

--Hdr

HEADERS AND FOOTERS FOR PRINT LAYOUT.

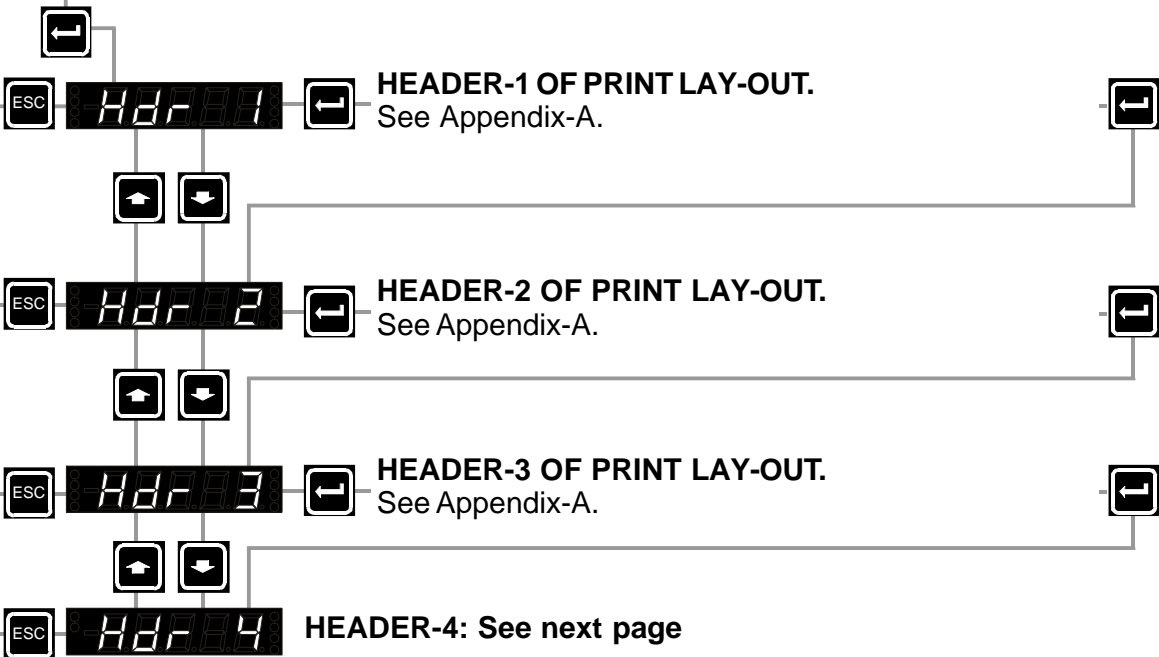

--OP9

FEATURE OPERATIONS : see next page.



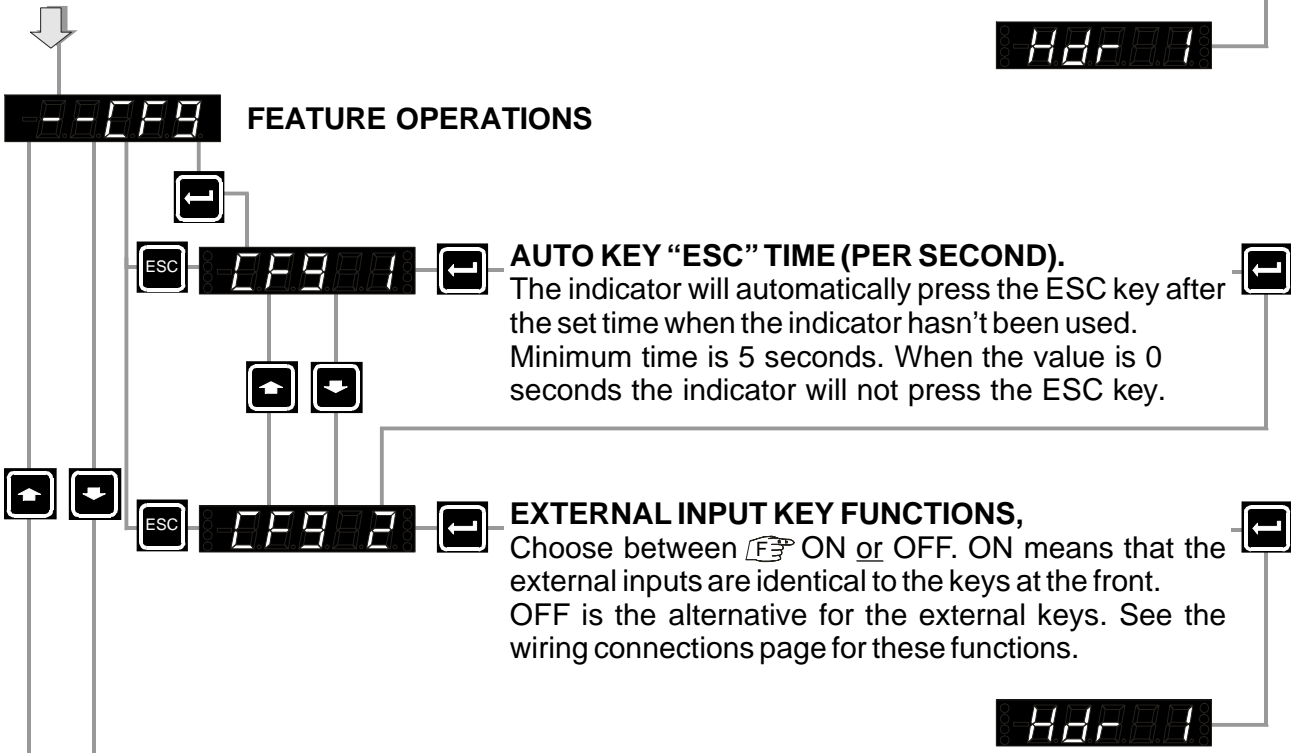
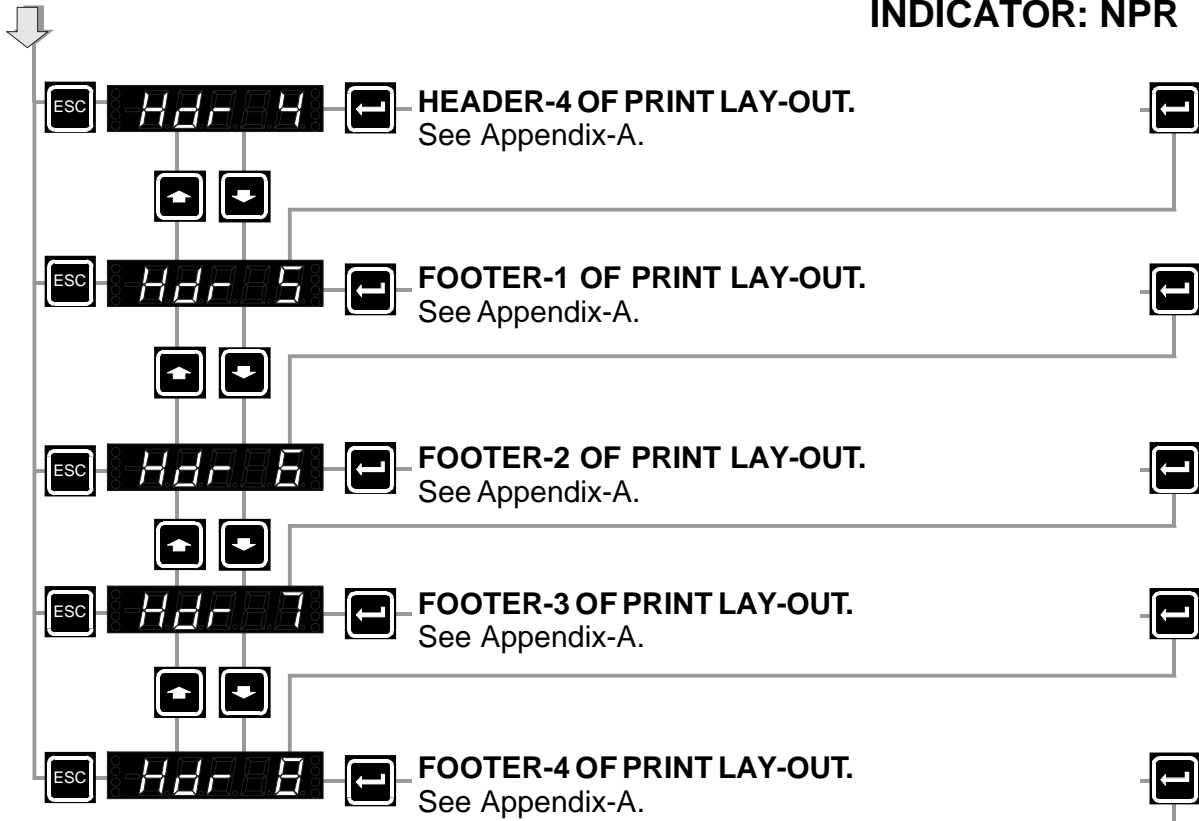

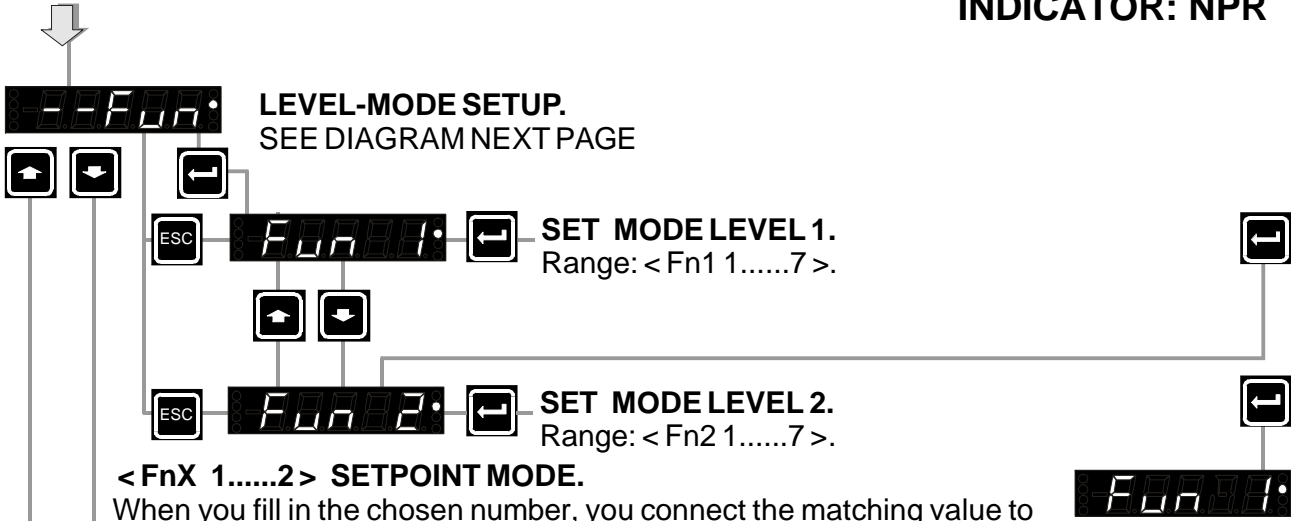

When you fill in the chosen number, you connect the matching value to the setpoint mode.

- 1 = Gross
- 2 = Net
- 3 = Filtered Gross (displ.fil 1 & fil 2)
- 4 = Filtered Net (displ.fil 1 & fil 2)
- 5 = Peak weight
- 6 = Valley weight
- 7 = Active tare weight

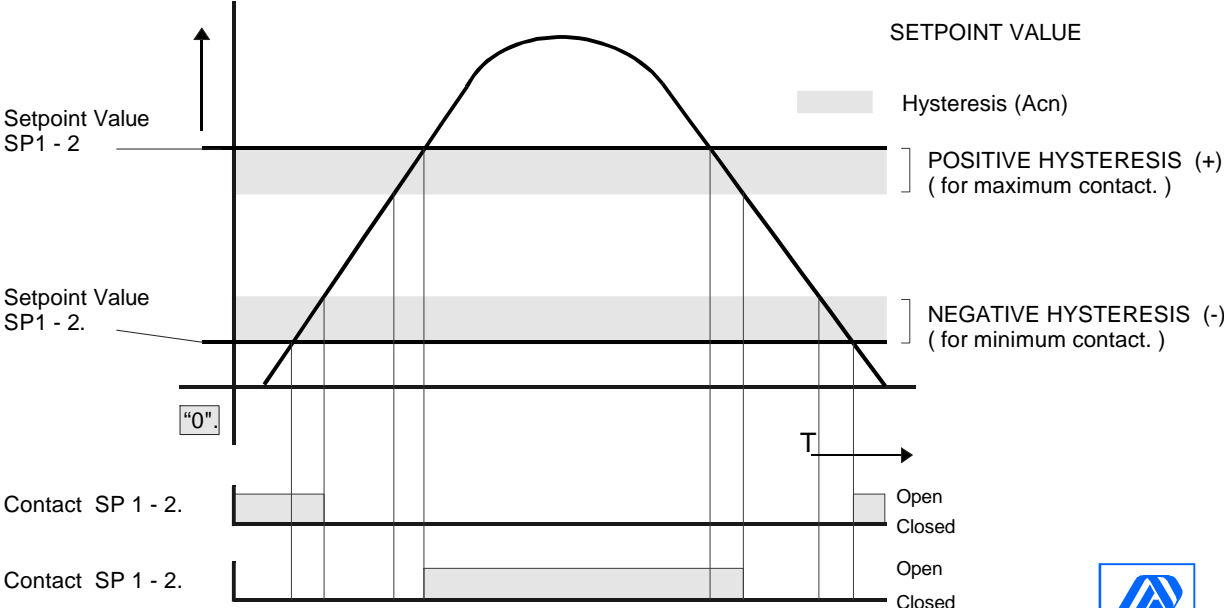
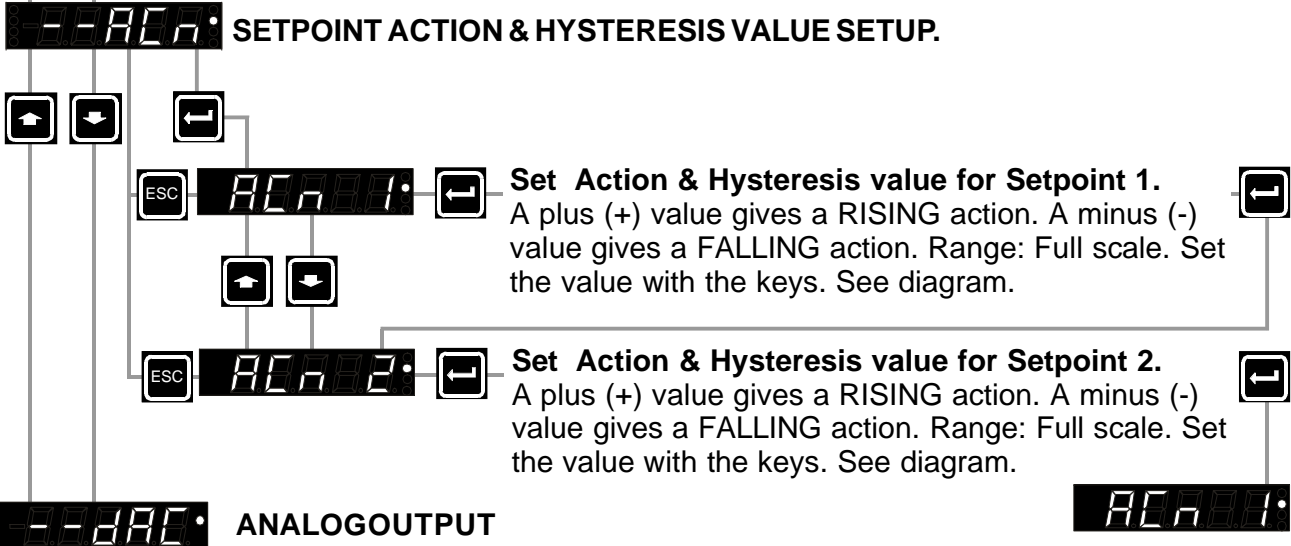

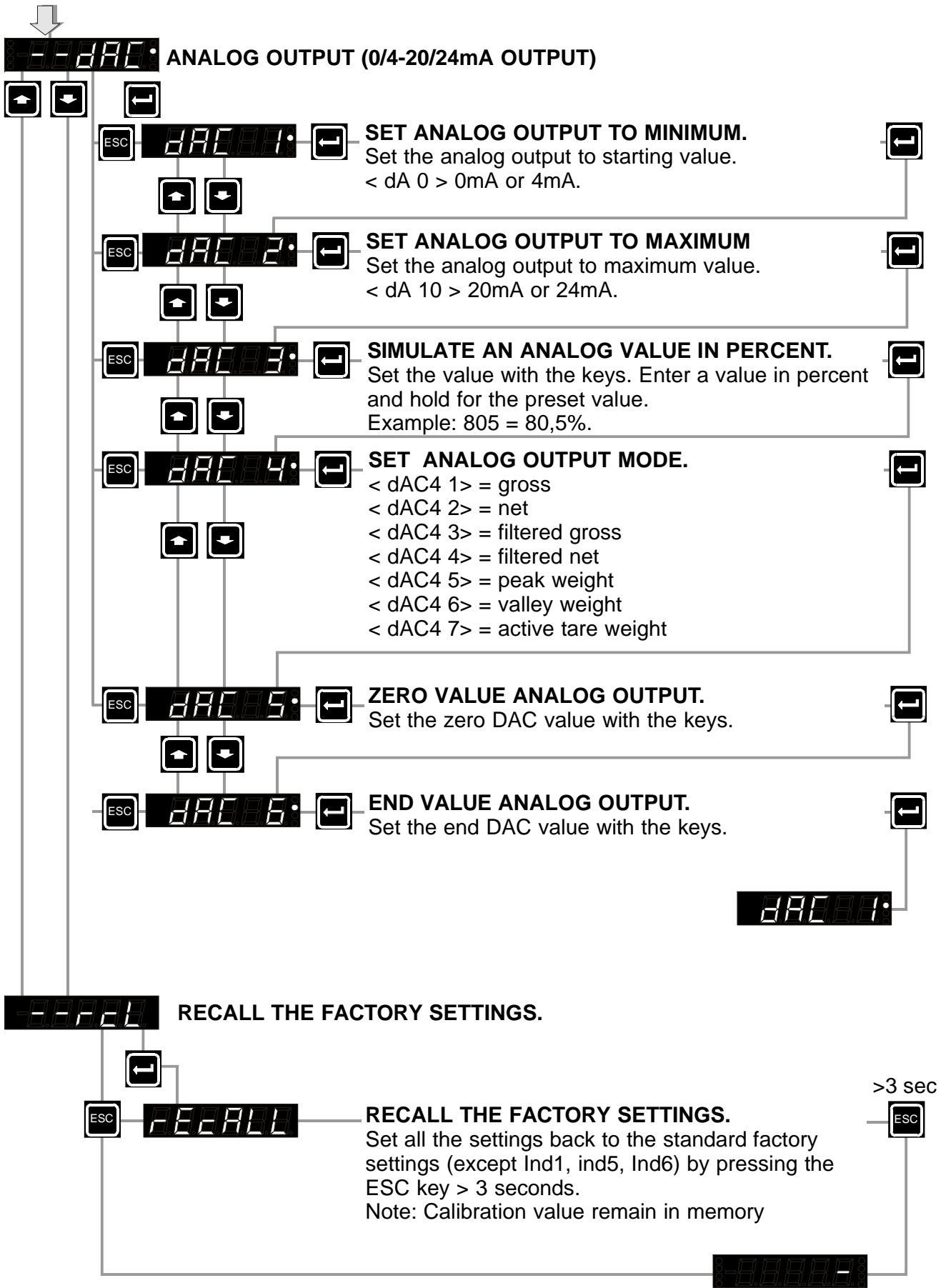





















## STANDARD FACTORY SETTINGS FOR NPR

DESCRIPTION	DISPLAY	VALUE	YOUR SETTING
The maximum display value	< Ind 1 >	2009	.....
No motion band	< Ind 2 >	3	.....
Zero tracking band	< Ind 3 >	3	.....
Digital overall filter	< Ind 4 >	2	.....
Display step size	< Ind 5 >	1	.....
Decimal point position	< Ind 6 >	none	.....
Display refreshment speed	< Ind 7 >	3	.....
Industrial or certified action	< Ind 8 >	In	.....
Sampling rate	< Ind 9 >	1000	.....
Stabilization time	< Ind 10 >	0.5	.....
Display filter band	< FIL 1 >	4	.....
Display filter factor	< FIL 2 >	1	.....
Zero suppressing	< FIL 3 >	2	.....
Polarity of input range.	< PCL 1 >	un	.....
Selection loadcell excitation.	< PCL 2 >	0.25	.....
Amplifier input sensitivity.	< PCL 3 >	2.0	.....
Change ADC offset (Dead load).	< PCL 4 >	5000	.....
Number of auto range steps	< rng 1 >	0	.....
Maximum auto range step size	< rng 2 >	20	.....
Reset of auto range step size	< rng 3 >	oF	.....
Communication baudrate port-1	< bdr 1 >	9.6	.....
Communication baudrate port-2	< bdr 2 >	9.6	.....
Communication protocol port-1	< port 1 >	PC	.....
Communication protocol port-2	< port 2 >	Pr	.....
Communication channel no. Port-1	< Chn 1 >	0	.....
Communication channel no. Port-2	< Chn 2 >	-	.....
Layout selection	< Prn 1 >	oF	.....
Form feed length	< Prn 2 >	00	.....
Left margin	< Prn 3 >	00	.....
End of line sequence selection	< Prn 4 >	CO	.....
Auto key "ESC" time	< CFG 1 >	30	.....
External input key function	< CFG 2 >	ON	.....
Setpoint-1 mode setup	< Fun 1 >	1	.....
Setpoint-2 mode setup	< Fun 2 >	2	.....
Action setpoint-1	< Acn 1 >	-2	.....
Action setpoint-2	< Acn 2 >	+2	.....
Analog output mode	< dAC 4 >	1	.....
Zero value analog output	< dAC 5 >	0	.....
End value analog output	< dAC 6 >	2000	.....

 = Factory setting



	Operation success
	Parameter error
	Input value is not valid
	Weigher not stable
	Parameter above maximum load
	Parameter below zero
	Not in zero range
	Arithmetic overflow occurred
	A/D reads all 1's
	A/D reads all 0's
	Gain reference < Zero reference
	Gain > 0.999984741211
	Flash ROM exhausted
	Error on header creation
	Error on data write
	Header validation failed
	De-active old data fail
	Item not found in store
	Error in stored data
	Bad calibration
	Action not enabled

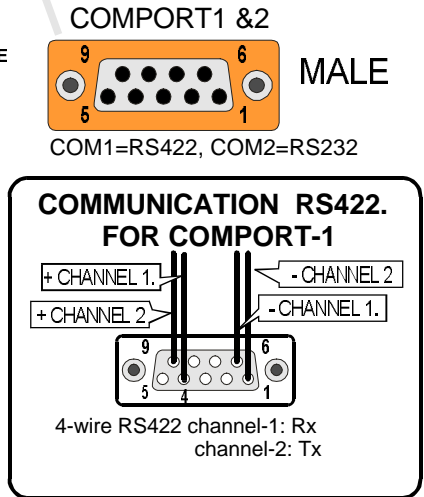
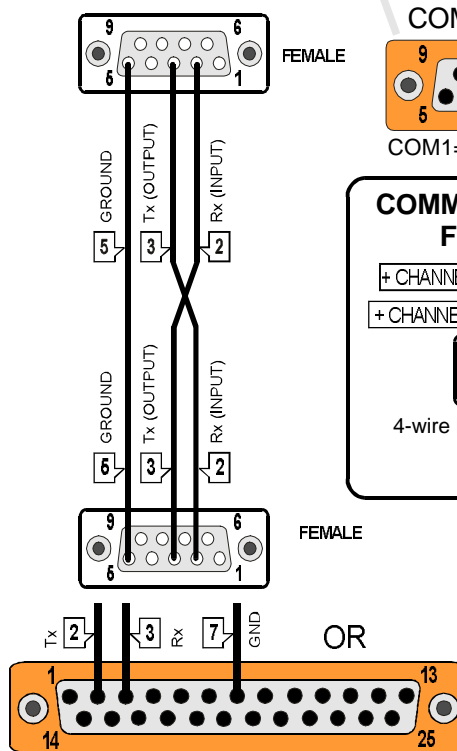
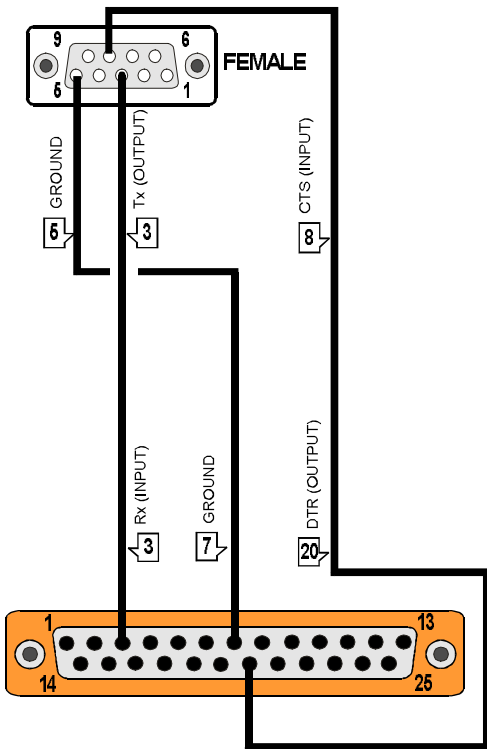
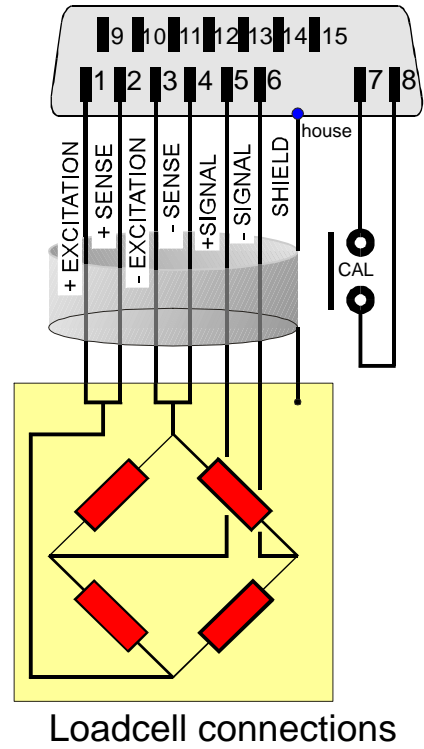
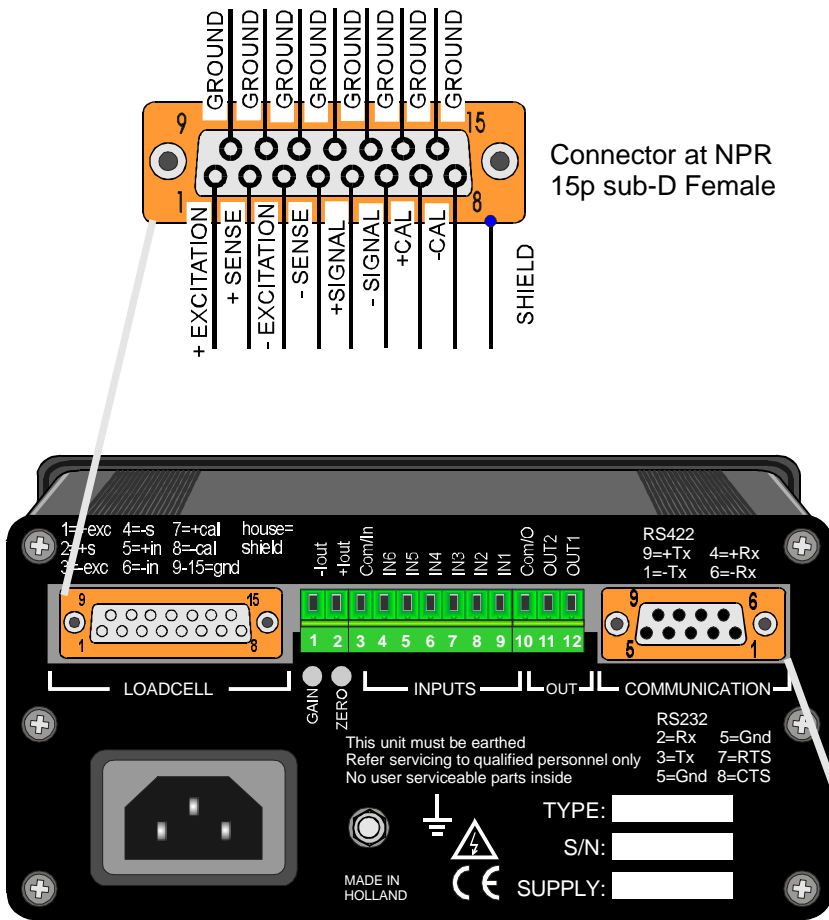

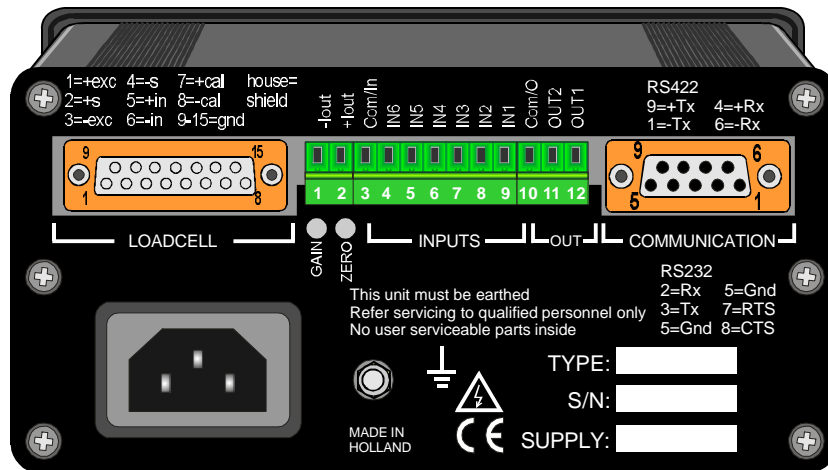

## Analog output (mA)

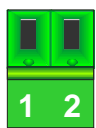

-Iout +Iout

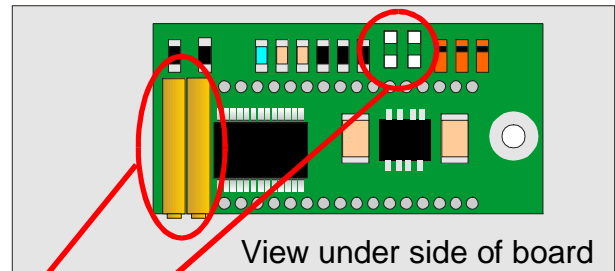
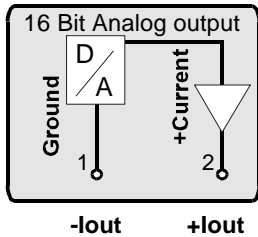

View under side of board

### Jumper setting analog output:

Open the housing to change the settings

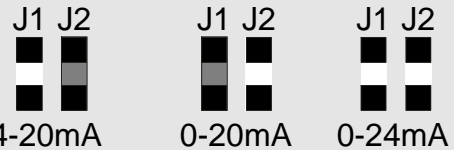

J1:	J2:	Output:
OFF	ON	4-20mA
ON	OFF	0-20mA
OFF	OFF	0-24mA

When necessary it's possible to correct the zero (0/4mA) or the gain (20/24mA) by using these potentiometers.

## Inputs definition

### Digital inputs 1-6

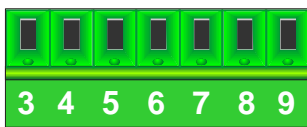

Common  
Input-6  
Input-5  
Input-4  
Input-3  
Input-2  
Input-1

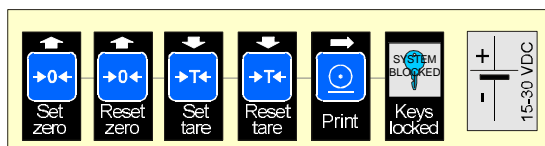

Menu setting: CFG2=OFF

**OR**

Menu setting: CFG2=ON (default)

### Digital outputs 1 & 2



Common  
Output-2  
Output-1

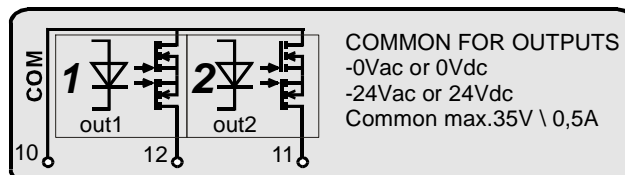

COMMON FOR OUTPUTS  
-0Vac or 0Vdc  
-24Vac or 24Vdc  
Common max.35V \ 0,5A

External Key-Control  
(opto isolated inputs)



## DIMENSIONS & MOUNTING

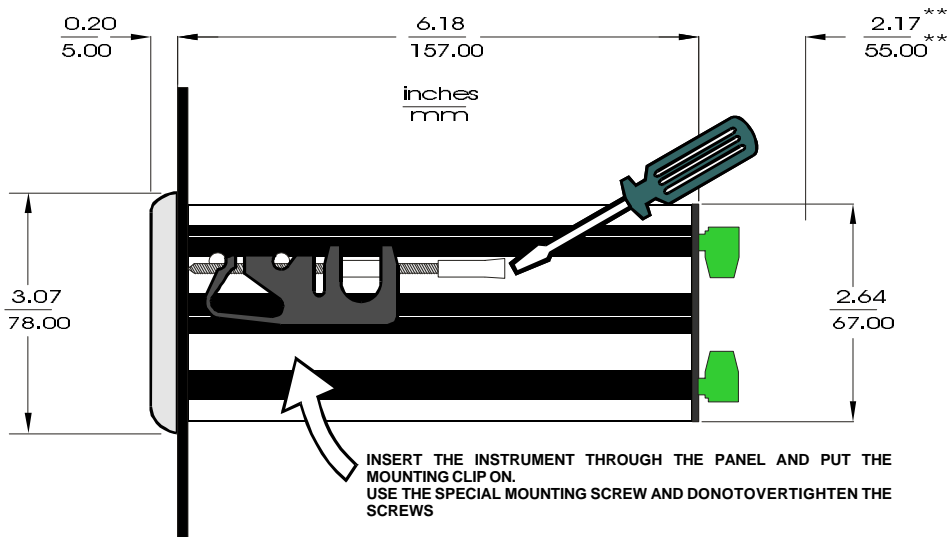

When the panel cut-out has been completed, unclip the mounts from the sides of the indicator and insert the instrument into the panel from the front.

On each side of the instrument you will find two mounting pins, use these two pins to reconnect the clips with the special mounting screw.

\*\*A space of 55mm is needed at the backside of the indicator due to the required of the power supply cable.

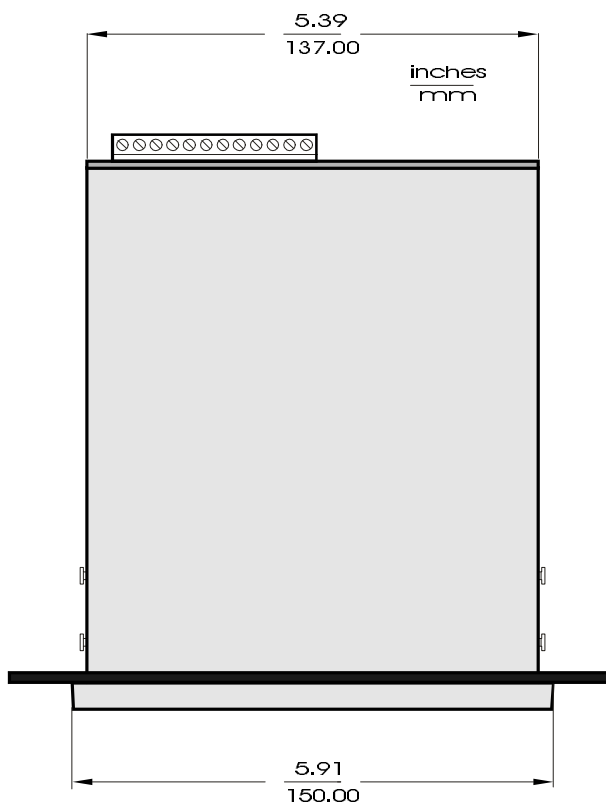

Be sure the panel is strong enough for the weight of the instrument.

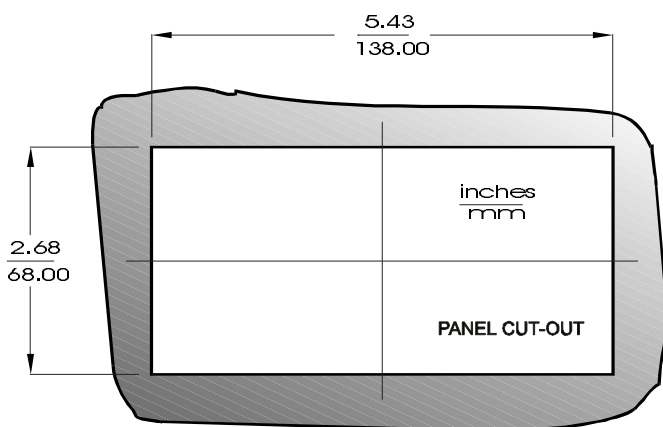

You can easily mount the instrument in a pre-cut panel.

The cut-out dimensions for this panel mounted instrument are standard DIN.

See the fig. on this page.

To setup the headers and footers you must connect a terminal to serial port-2 (RS232) of the indicator. Instead of using a terminal you can use a PC running a terminal emulation package like Procomm or Telemate. Make sure the terminal is set to the baudrate set using the < --bdr >-menu option for comport-2. The data format used is 8 databits, 2 stopbits, no parity.

After activating the < --hDr > menu you can select one of the headers or footers, < hDr 1 > to < hDr 8 >. Header 1-4 are headers and header 5-8 are footers.

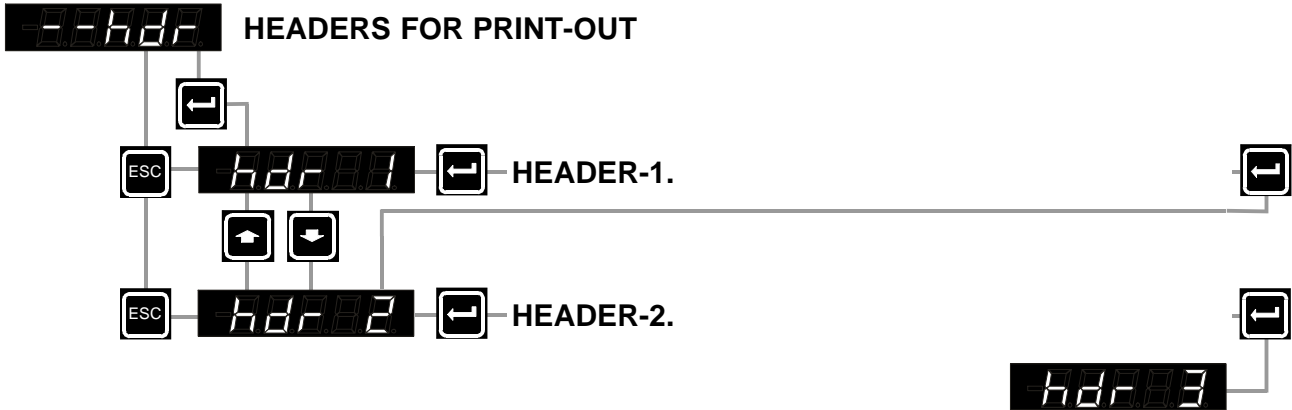

After selecting a header or footer the indicator will show a "KIT" scanner and a prompt is displayed on the terminal showing the current header line, for example:  
HEADER 1: [-- Penko Engineering ---]

The cursor is positioned on the last used string position. By pressing the backspace key at the terminal you can rub-out any of the previous entered characters until the complete string is erased. Enter the new string by simply typing the desired text into the prompted area, up to **24** characters of text are allowed. To confirm the new input the indicator will beep on each character entered. When you have reached the beginning or the end of the header the indicator will beep for a longer period.

After selecting the header line you can press the "UP"-key at the indicator to verify the line. This feature is also handy when experiencing problems with the terminal connection. By pressing the ">0<"-key for over 3 seconds you can erase the header line completely, alternatively you can erase the line by simply rubbing out all characters.

Empty header lines will be skipped during printing so if you only want one header line, only enter the first line and erase all other lines.

If the prompt looks something like this:

HEADER 1: [

instead of

HEADER 1: [\_\_\_\_\_]

check the 'non-destructive backspace' option on the terminal, this must be set to off.



**B1:**

**PRINTER TICKET LAYOUTS:**

Standard ticket: Prn1 =1 \ Prn2 = 0\ Prn3 =5

Standard ticket:

```

----- Header 1 -----
----- Header 2 -----
----- Header 3 -----
----- Header 4 -----
-----
30-10-01  22:13:38
NR:                19

N                483 kg
T                 0 kg
(P)T             12 kg
----- +
B/G              495 kg

CODE            000001
-----
----- Footer 1 -----
----- Footer 2 -----
----- Footer 3 -----
    
```

Actual weight

Total ticket:

```

----- Header 1 -----
----- Header 2 -----
----- Header 3 -----
----- Header 4 -----
-----
30-10-01  22:13:48
NR:                19

TOT NET         4557 kg
TOT TARE         0 kg
TOT PTARE       200 kg
----- +
TOT GROSS       4757 kg

CODE            000001
-----
----- Footer 1 -----
----- Footer 2 -----
----- Footer 3 -----
----- Footer 4 -----
    
```

Reset number of weighings  
Total remains in memory

Day total ticket:

```

----- Header 1 -----
----- Header 2 -----
----- Header 3 -----
----- Header 4 -----
-----
30-10-01  22:13:48
NR:                19

DAY NET         4557 kg
DAY TARE         0 kg
DAY PTARE       200 kg
----- +
DAY GROSS       4757 kg

CODE            000001
-----
----- Footer 1 -----
----- Footer 2 -----
----- Footer 3 -----
----- Footer 4 -----
    
```

Reset number of weighings  
and reset of total weight.

**B2:**

Ticket printing of 3 dosings with automatic total: Prn1=2 \ Prn2 = 0\ Prn3 =5

Total ticket:

```

----- Header 1 -----
----- Header 2 -----
----- Header 3 -----
----- Header 4 -----
-----
NR (P)TARE kg  NET kg
1 P      100    523
2 P      100    523
3        145    468
-----
22:35:40    3  30-10-01
CODE                000001

TOT NET         1514 kg
TOT TARE         145 kg
TOT PTARE       200 kg
----- +
TOT GROSS       1859 kg
TOT GROSS       1859 kg

-----
----- Footer 1 -----
----- Footer 2 -----
----- Footer 3 -----
----- Footer 4 -----
    
```

Reset number of weighings  
Total remains in memory

Day total ticket:

```

----- Header 1 -----
----- Header 2 -----
----- Header 3 -----
----- Header 4 -----
-----
22:34:44    2  30-10-01
CODE                000001

DAY NET         975 kg
DAY TARE        144 kg
DAY PTARE       100 kg
----- +
DAY GROSS       1219 kg

-----
----- Footer 1 -----
----- Footer 2 -----
----- Footer 3 -----
----- Footer 4 -----
    
```

Reset number of weighings  
and reset of total weight.



---

## Appendix-C: PC Protocol description for NPR

### ASCII protocol format:

Baudrate 110/150/300/600/1200/2400/4800/9600/19k2/38k4/57k6/115k2  
Data bits 8-bits  
Stop bits 1-bit  
Parity NONE

### ASCII protocol commands:

#### Single shot commands

Command	Response strings	Operation
OP <number><CR>	OK<CR>/ERR<CR>	Open channel connection
CL<CR>		Close channel connection
SZ<CR>	OK<CR>/ERR<CR>	Set Zero value
RZ<CR>	OK<CR>/ERR<CR>	Reset Zero value
ST<CR>	OK<CR>/ERR<CR>	Set Tare
RT<CR>	OK<CR>/ERR<CR>	Reset Tare
PT<value><CR>	OK<CR>/ERR<CR>	Get/Set Preset Tare
PS<CR>	OK<CR>/ERR<CR>	Activate preset Tare
S1<value><CR>	OK<CR>/ERR<CR>	Get/Set setpoint-1
S2<value><CR>	OK<CR>/ERR<CR>	Get/Set setpoint-2
H1<value><CR>	OK<CR>/ERR<CR>	Get/Set setpoint-1 hysteresis
H2<value><CR>	OK<CR>/ERR<CR>	Get/Set setpoint-2 hysteresis
A1<value><CR>	OK<CR>/ERR<CR>	Get/Set setpoint-1 action
A2<value><CR>	OK<CR>/ERR<CR>	Get/Set setpoint-2 action
<div style="border: 1px solid black; padding: 5px; margin: 10px 0;"><p>Possible values for A1/A2 commands:</p><ul style="list-style-type: none"><li>0 Fast gross weight</li><li>1 Fast nett weight</li><li>2 Display gross weight</li><li>3 Display nett weight</li><li>4 Peak weight</li><li>5 Valley weight</li><li>6 Active tare weight</li></ul></div>		
SS<CR>	OK<CR>/ERR<CR>	Save level setup
RP<CR>	OK<CR>/ERR<CR>	Reset Peak
RV<CR>	OK<CR>/ERR<CR>	Reset Valley
GD<CR>	OK<CR>/ERR<CR>	Get Display value
GN<CR>	N+00000<CR>	Get net
GG<CR>	G+00000<CR>	Get gross
GP<CR>	P+00000<CR>	Get peak
GV<CR>	V+00000<CR>	Get valley
GF<CR>	F+00000<CR>	Get fast net (no display damping)
GS<CR>	S+00000<CR>	Get A/D sample
GW<CR>	W+00000+00000SSCC<CR>	Get long net+gross, status & csum
GX<CR>	X+00000<CR>	Get extended net (net x 10)

---

## Appendix-C: PC Protocol description for NPR

LW<CR>	W+00000+00000SSCC<CR>/ERR<CR>	Get long net+gross, status&csum
LF<CR>	F+00000+00000SSCC<CR>/ERR<CR>	Get long fast net+gross, status&csum
LN<CR>	N+00000+00000SSCC<CR>/ERR<CR>	Get net+fast net , status & csum
LX<CR>	X+00000+00000SSCC<CR>/ERR<CR>	Get long extended net (net x 10)+ extended gross (gross x 10), status & csum
SD<CR>	OK<CR>/ERR<CR>	Set auto-transmit display value
SN<CR>	OK<CR>/ERR<CR>	Set auto-transmit net
SG<CR>	OK<CR>/ERR<CR>	Set auto-transmit gross
SW<CR>	OK<CR>/ERR<CR>	Set auto-transmit long weight
SP<CR>	OK<CR>/ERR<CR>	Set auto-transmit peak
SV<CR>	OK<CR>/ERR<CR>	Set auto-transmit valley
SF<CR>	OK<CR>/ERR<CR>	Set auto-transmit fast net
SX<CR>	OK<CR>/ERR<CR>	Set auto-transmit extended net (net x 10)
IV<CR>	V:0102<CR>	Information on Version
ID<CR>	D:0502<CR>	Information on Device
IS<CR>	S:001000<CR>	Information on System

### IS command status bits:

The response string are 2 decimal bytes from each 3 characters. The first byte represents the on/off state of the display LEDs. The second byte represents the blinking state of the LEDs.

bit-1 stable	bit-16 menu
bit-2 zero	bit-32 memo
bit-4 net	bit-64 L1 (setpoint-1)
bit-8 F1 (not defined)	bit-128 L2 (setpoint-2)